



technical drawing

school of art, design and architecture
nust – spring 2011

<http://www.youtube.com/watch?v=E55OcGB0L8o>



technical drawing



the ability to 'document imagination'.

Drawing technically?

Drawings are used by architects to

- **develop ideas** and concepts
- to **communicate** design idea into a coherent proposal
- to **convince clients** of the merits of a design
- to **enable** a building contractor to construct it

Standards and conventions for layout, line thickness, text size, symbols, view projections and architectural drawings are drawn according to a set of conventions, which include particular views floor plan, section , elevations etc.

set of rules?

w“right” to remember?





f o c u s



BE PRESENT
EVERY DAY

TO-DO LIST

~~NOTHING~~

A cartoon illustration of a hand holding a pencil, crossing out the word 'NOTHING' on a piece of paper titled 'TO-DO LIST'. The paper is held by another hand. The background is a textured, light green surface.

Late submissions

Not acceptable?

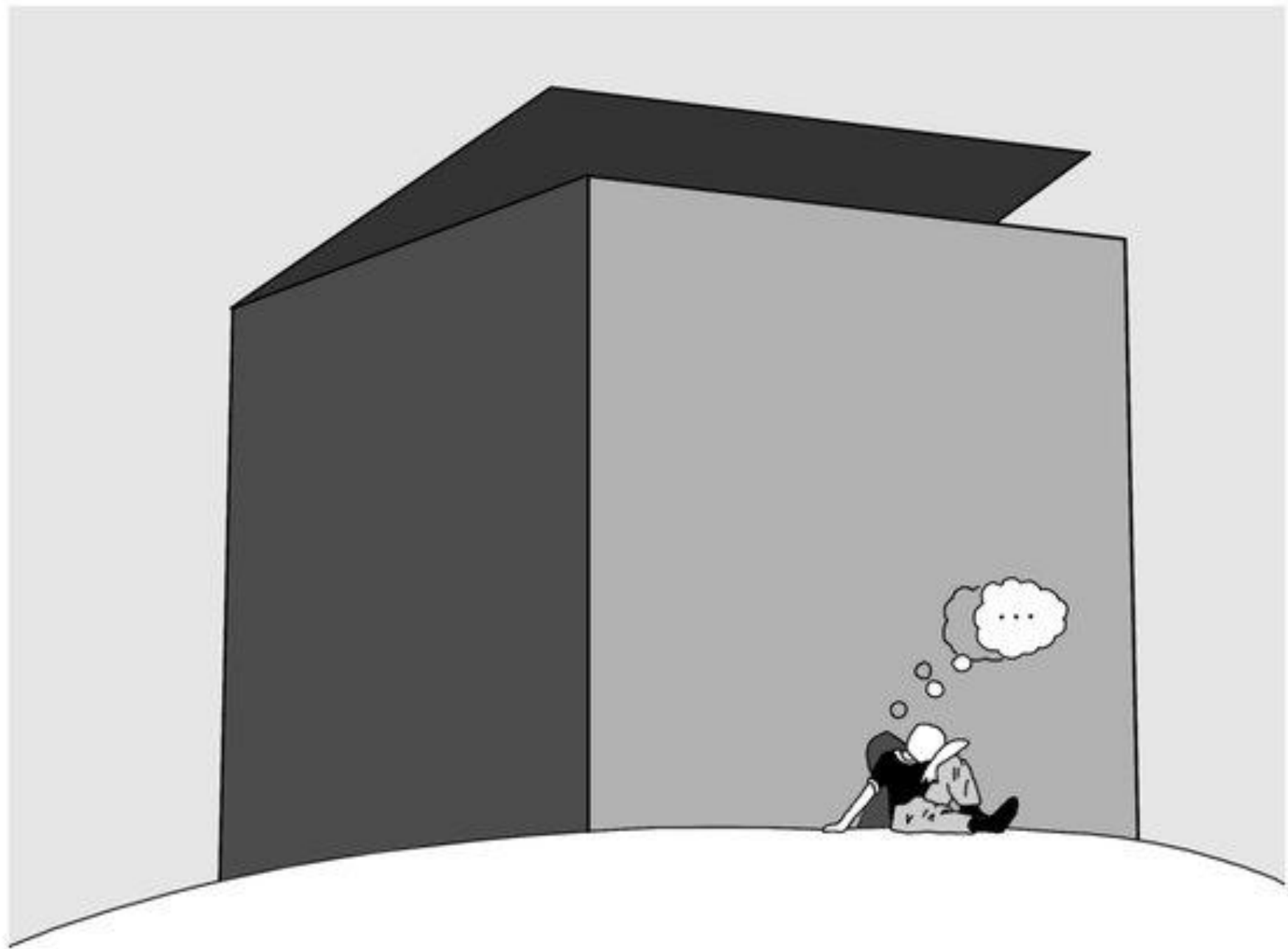

but it's so peaceful here...



BEFORE YOU
THINK OUTSIDE THE BOX
YOU NEED A BOX.



Shtiki.com

Buy the reader

Make your life easier?

KISS

KEEP
IT
SIMPLE
STUPID

technical drawing introduction

- what is technical drawing?
- architectural vocabulary?
- what will **you** learn in this class?
- final outcome? what is expected from **you**?



Intro to technical drawing
sada, spring 2010

technical drawing introduction

what is technical drawing?

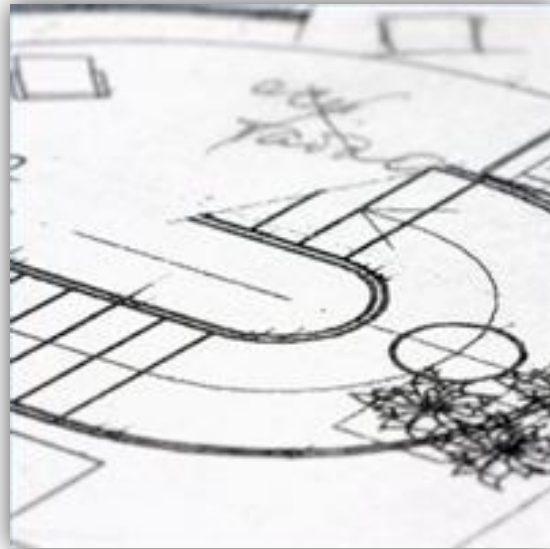

It is a formal and precise way of **communicating Information and design through drawings** about the shape, size, features and precision of physical objects, buildings, their exterior, interior and the context.

It can be done by using freehand, mechanical or computer methods



Intro to technical drawing
sada, spring 2010

Drawings lead to realization

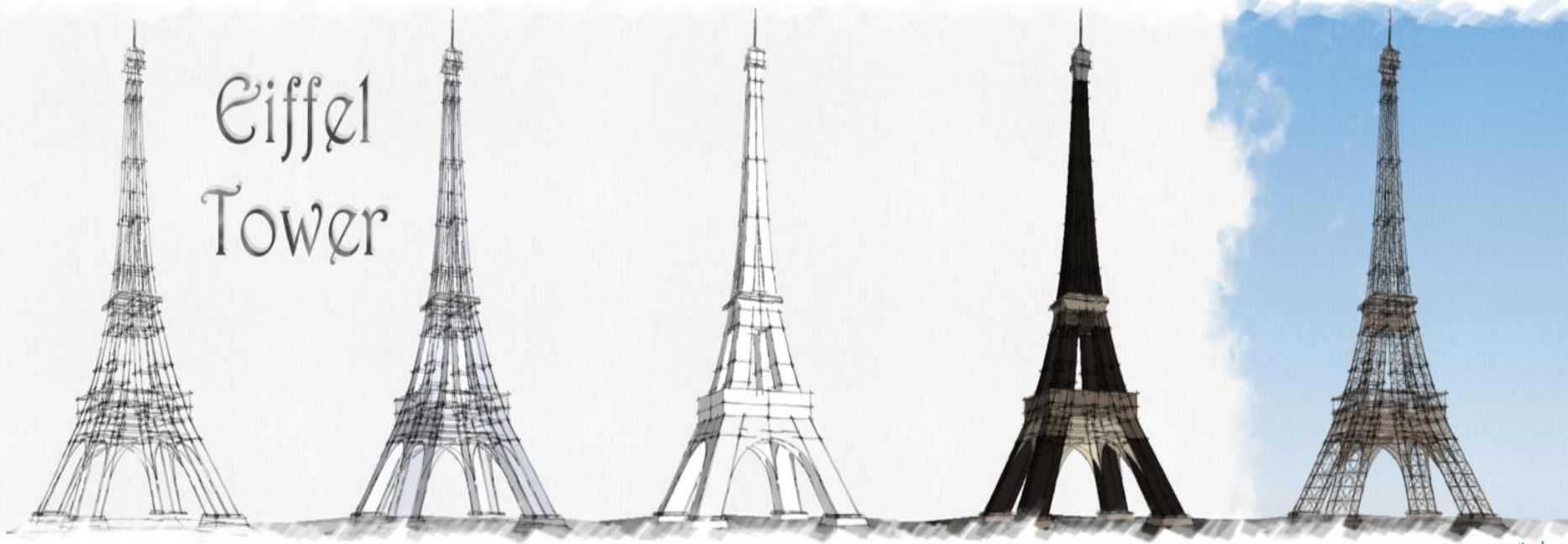

Thinking with a pencil



Intro to technical drawing
Eiffel tower

technical drawing introduction

How to make technical drawings?

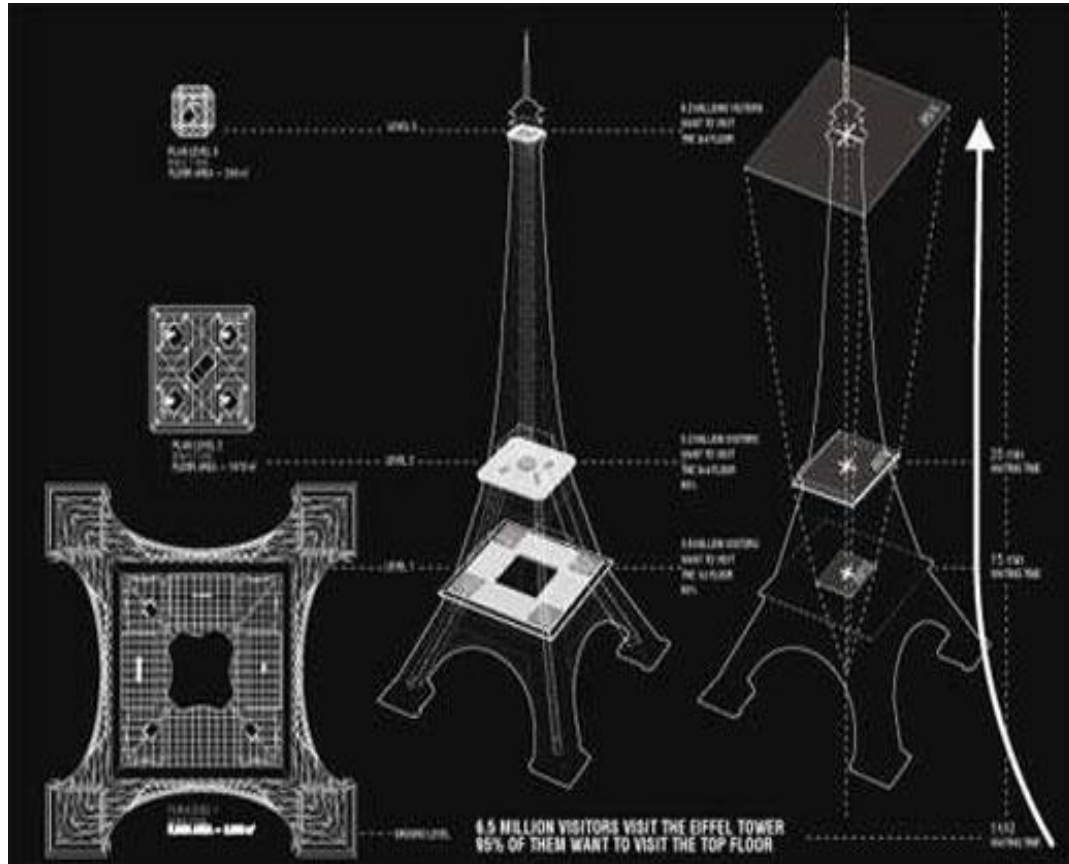

Generally, technical drawing is the expression of bodies (or matters) by lines.

Technical drawings contain geometric figures and symbols to convey the scope and details of the project.

Drawing usually means using drawing instruments, from compasses to computers, to bring precision to the drawings.



Intro to technical drawing
sada, spring 2010

technical drawing introduction

architectural vocabulary

section

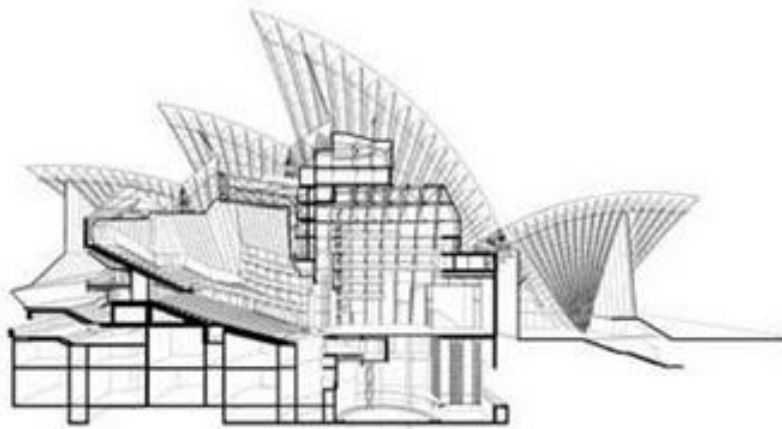

elevation

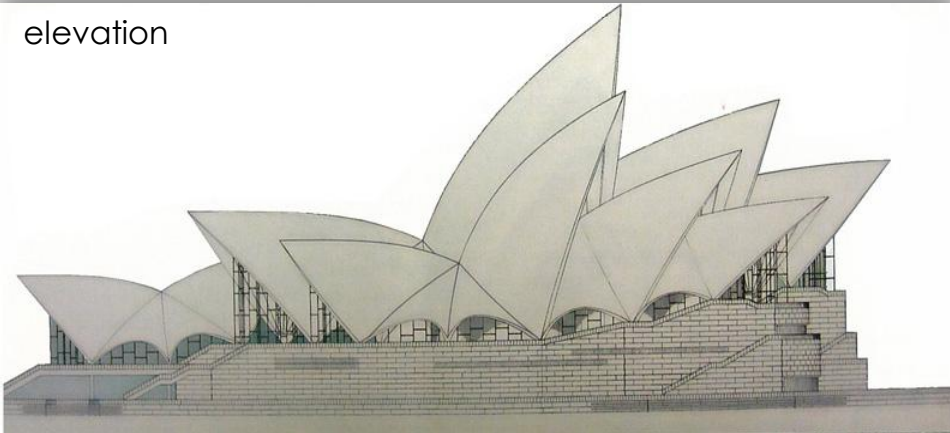

Drawings leading to realization.



Intro to technical drawing
Sydney Opera house

technical drawing introduction

vocabulary of technical drawings

plan

a drawing made to scale to represent **the top view** or a **horizontal section** of a structure or an area.

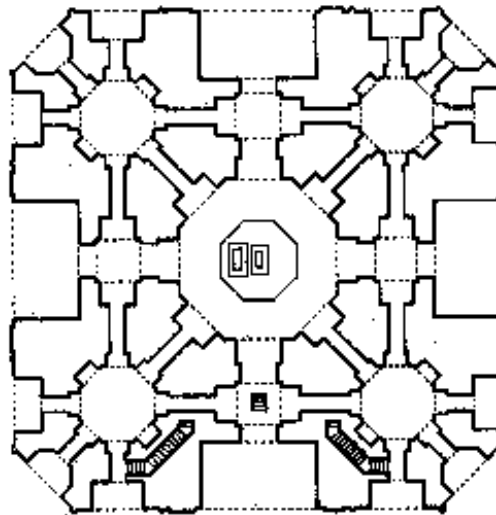
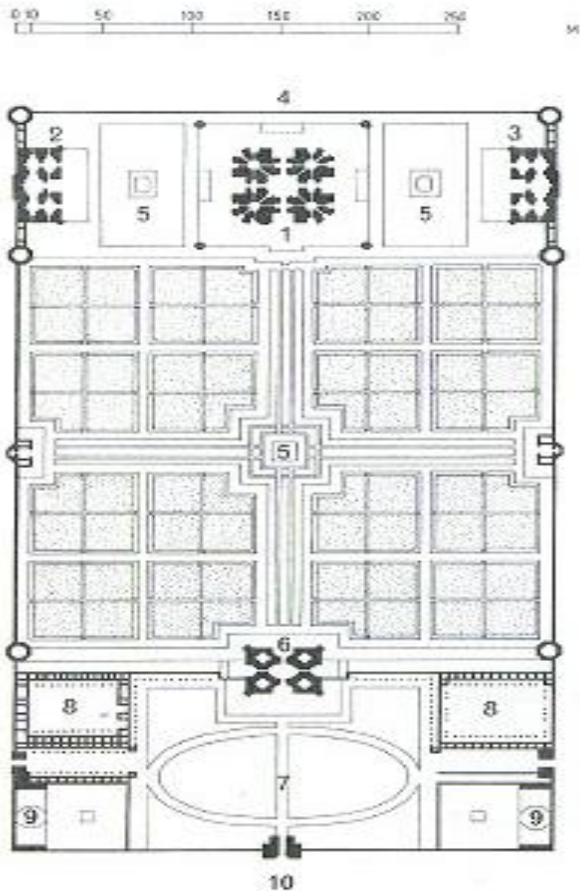

D | Intro to technical drawing
plan of taj mahal, india

technical drawing introduction

vocabulary of technical drawings

elevation

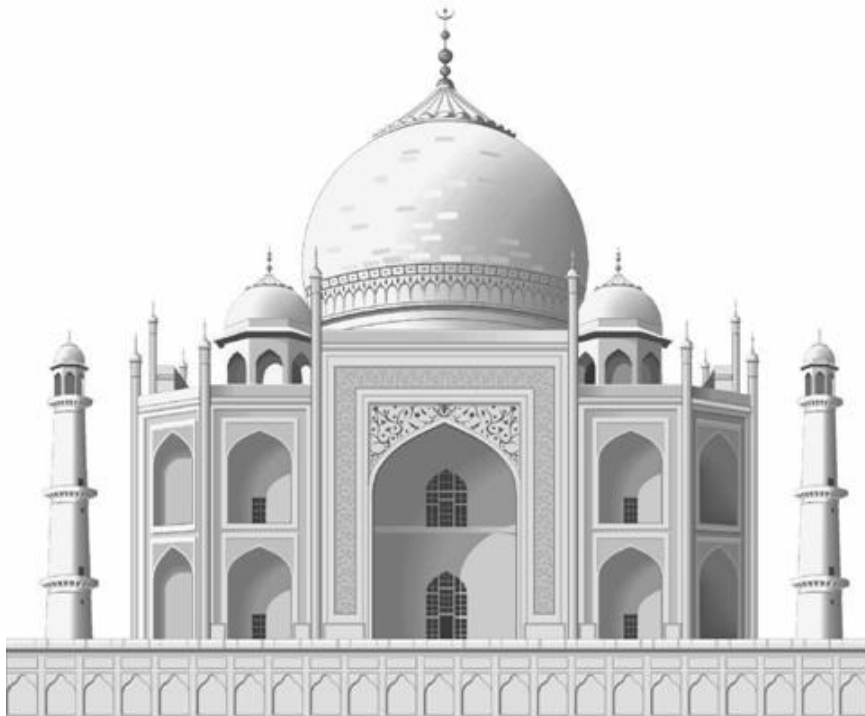

South elevation



It's a drawing of **each side** of a building - **the front, the rear and the sides**, showing what it will look like after completion.



Intro to technical drawing
elevation of taj mahal, india

technical drawing introduction

vocabulary of technical drawings

elevation

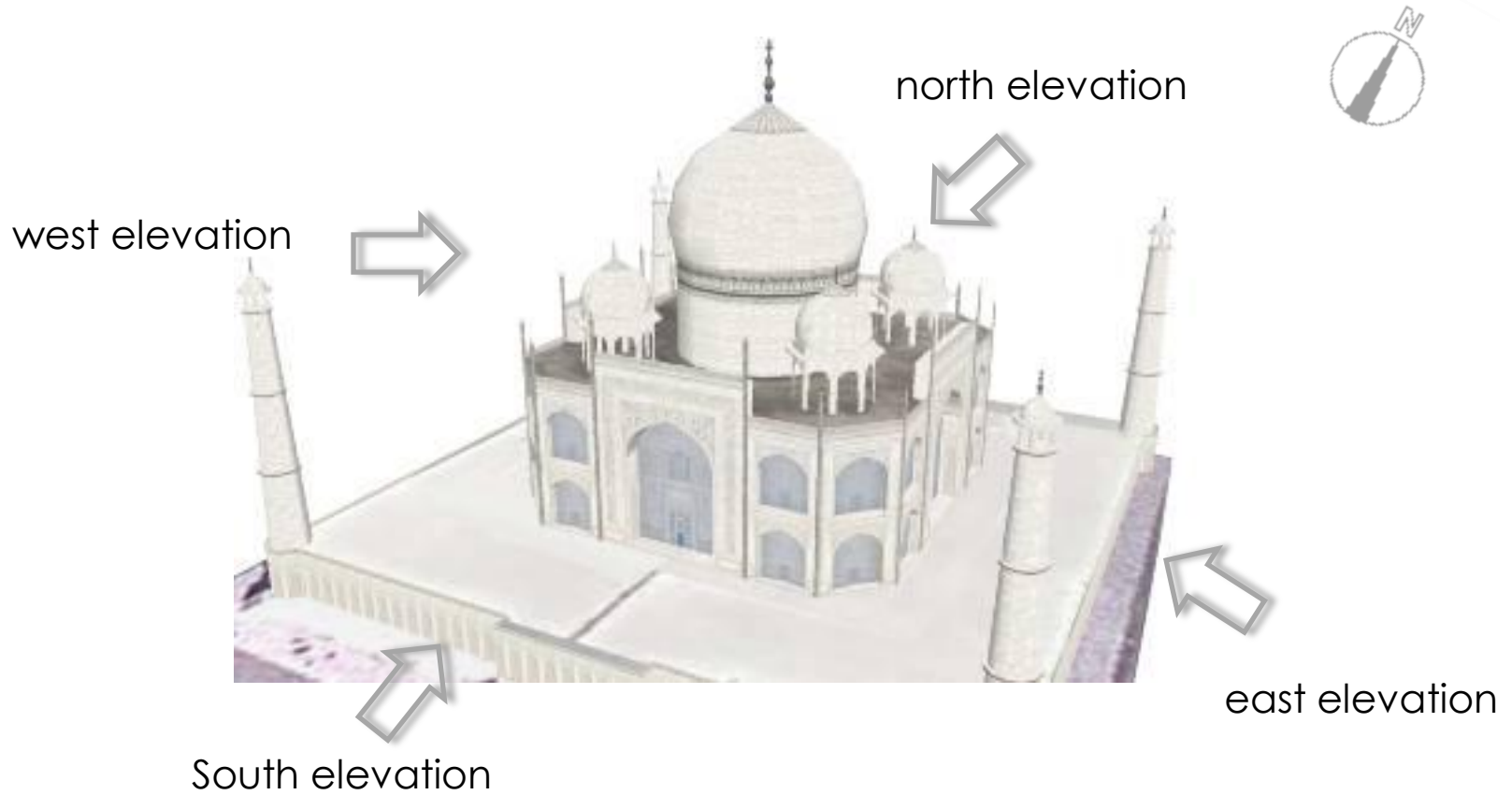

technical drawing introduction

Vocabulary of technical drawings

section

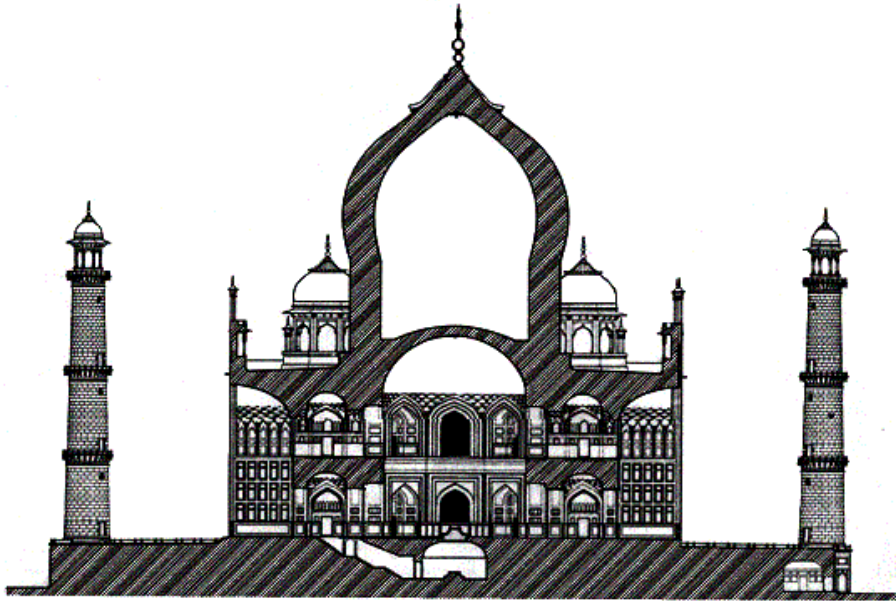

Section of the Taj Mahal (1631-48)

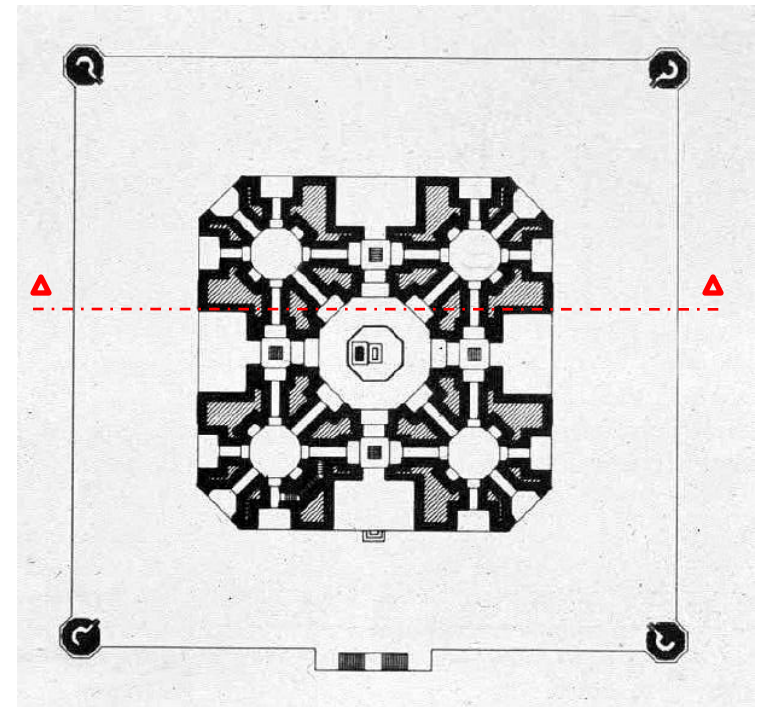

a representation of an object as it would appear if **cut by a plane**, showing its internal structure.



Intro to technical drawing
section of taj mahal, india

technical drawing introduction

Vocabulary of technical drawings

3D views

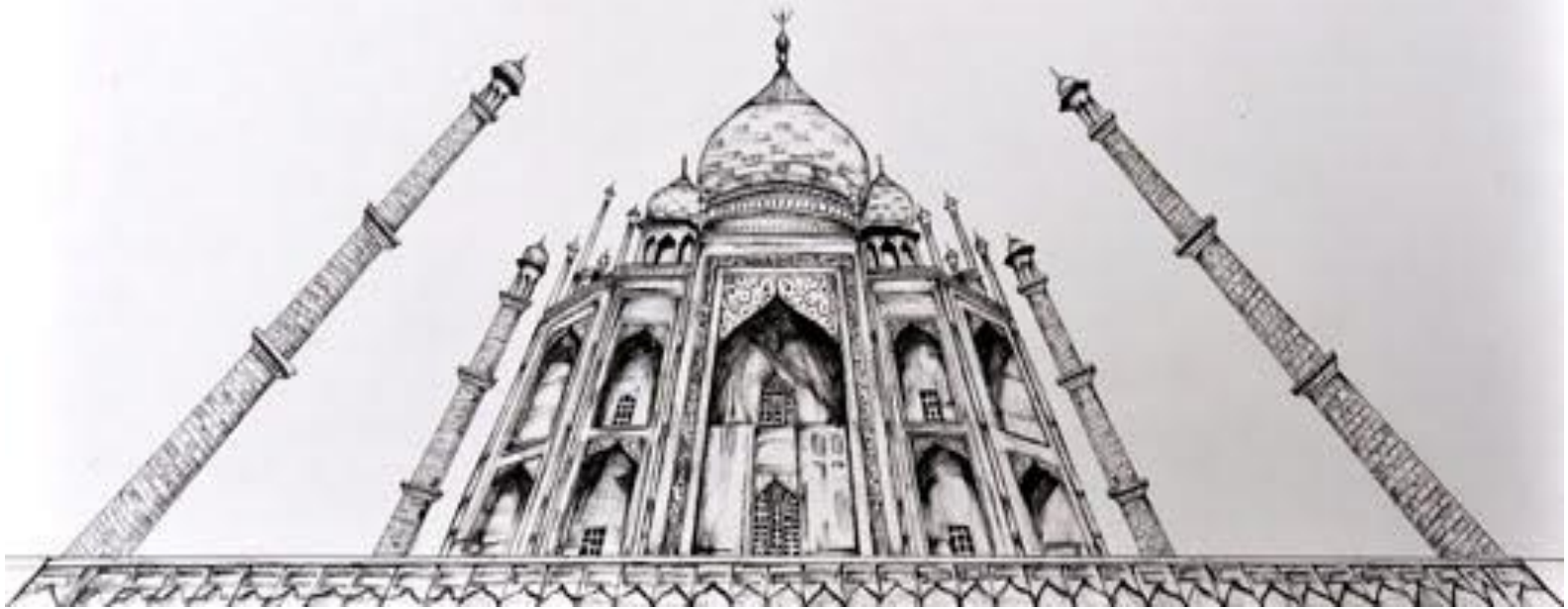

Intro to technical drawing
taj mahal, india

technical drawing introduction

Vocabulary of technical drawings

3D views

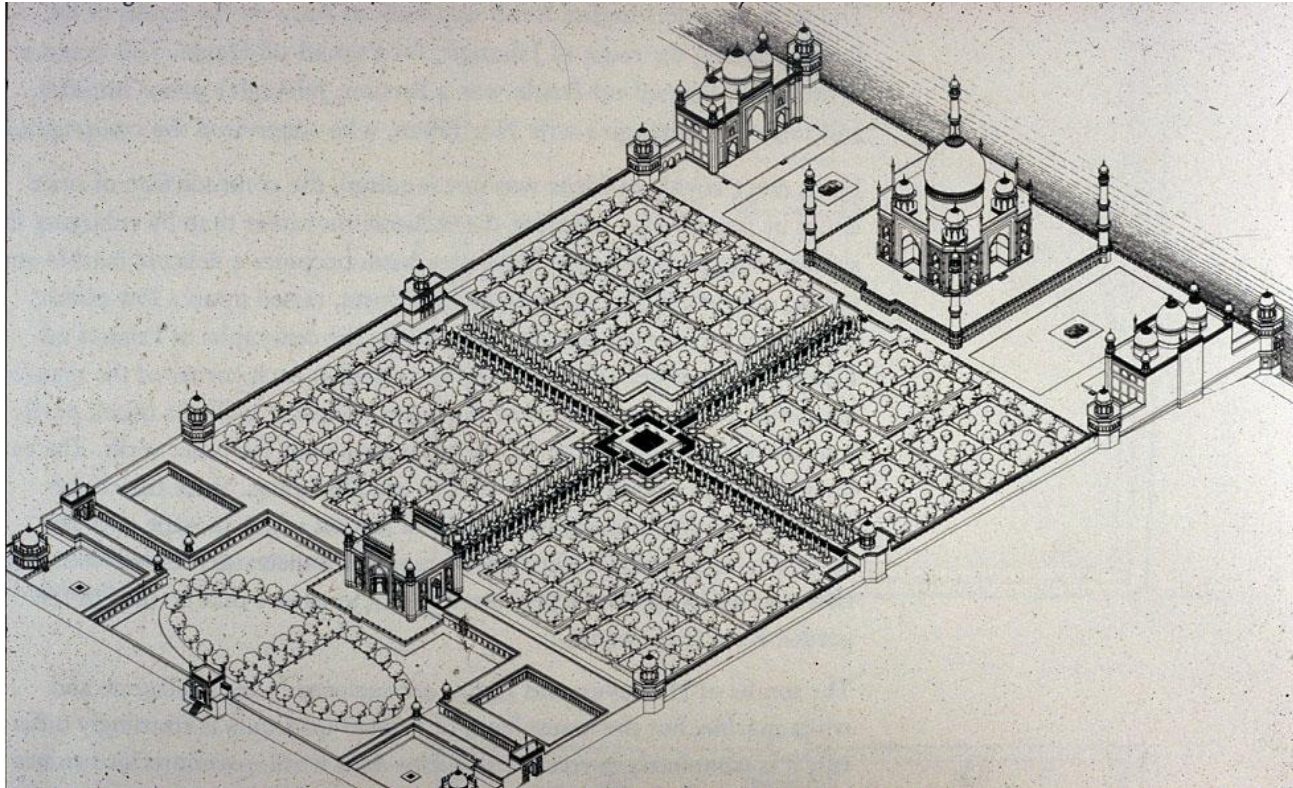

technical drawing introduction

Tools used for technical drawings

Manual drafting tools

pencils



A SHARP POINT WILL BREAK.



A SLIGHTLY ROUNDED POINT IS BEST.

Figure 2-1. Use a slightly rounded point on the pencil.

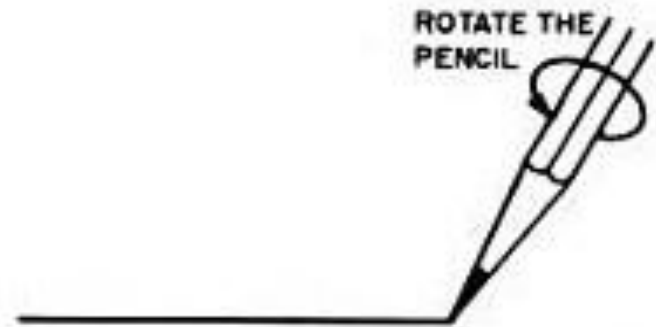

Figure 3-2. When drawing lines with a wood-cased or mechanical pencil, rotate the pencil to get a uniform line width.

HB are generally preferred.



Intro to technical drawing
pencil

technical drawing introduction

Tools used for technical drawings

Manual drafting tools

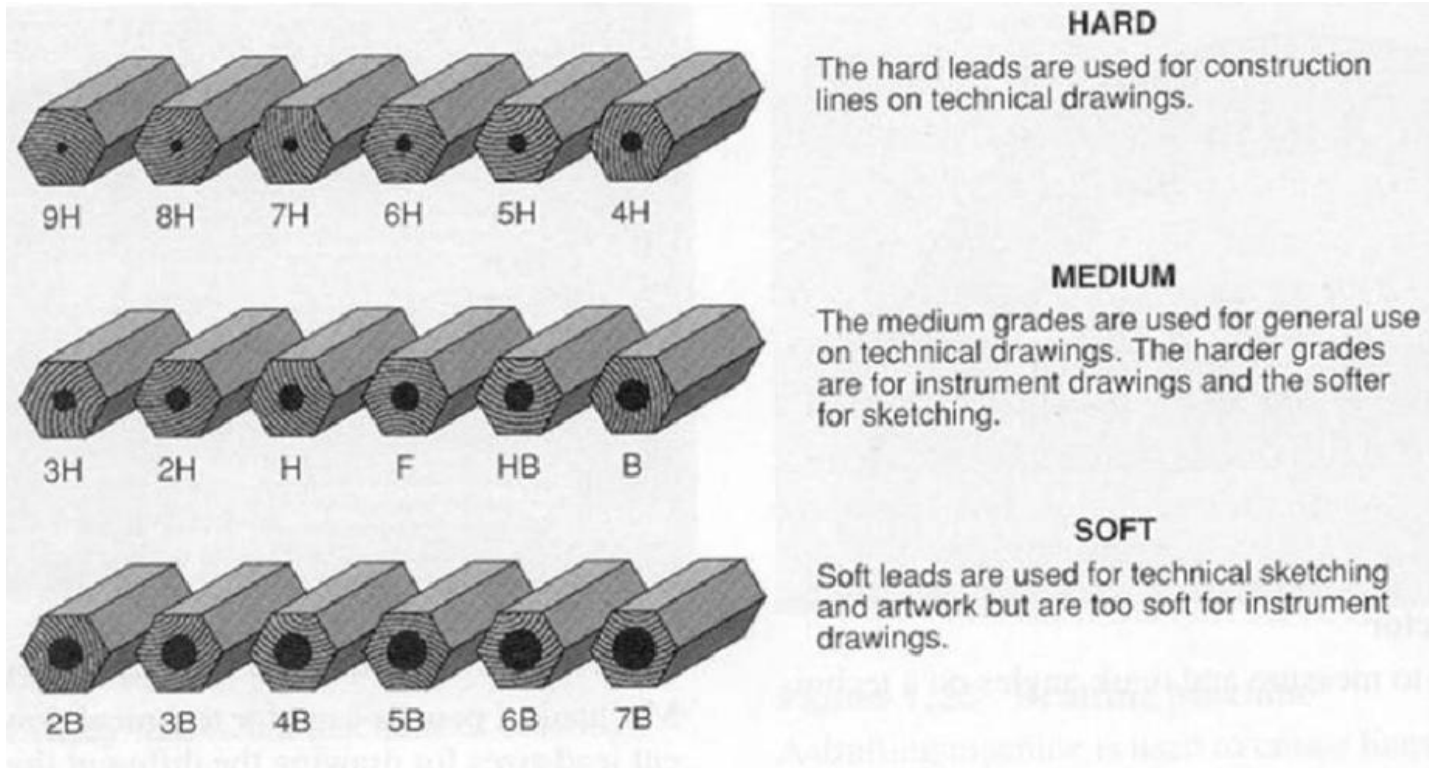

technical drawing introduction

Tools used for technical drawings

Manual drafting tools

One set of 45- and 30/60 degree triangles

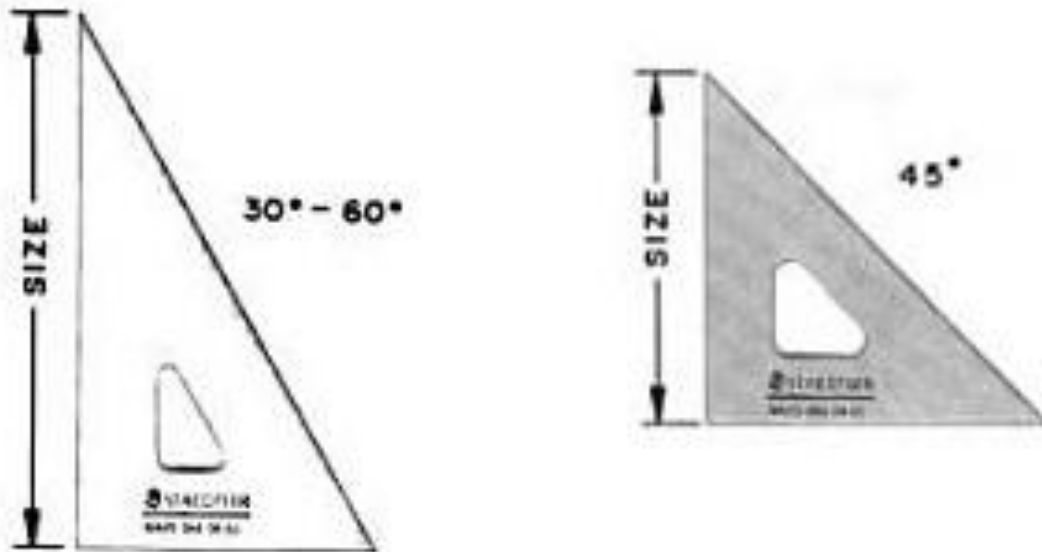

Figure 1-7. Triangles used with the parallel straightedge to draw vertical lines and angles. (Courtesy Staedtler, Inc.)

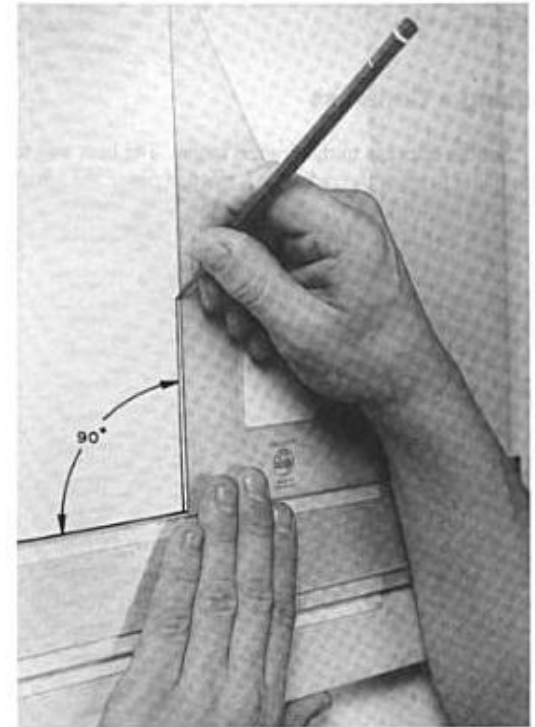

Figure 3-13. How to draw a line perpendicular to a horizontal line with a triangle and parallel straightedge.



Intro to technical drawing
set squares/triangles

technical drawing introduction

Tools used for technical drawings

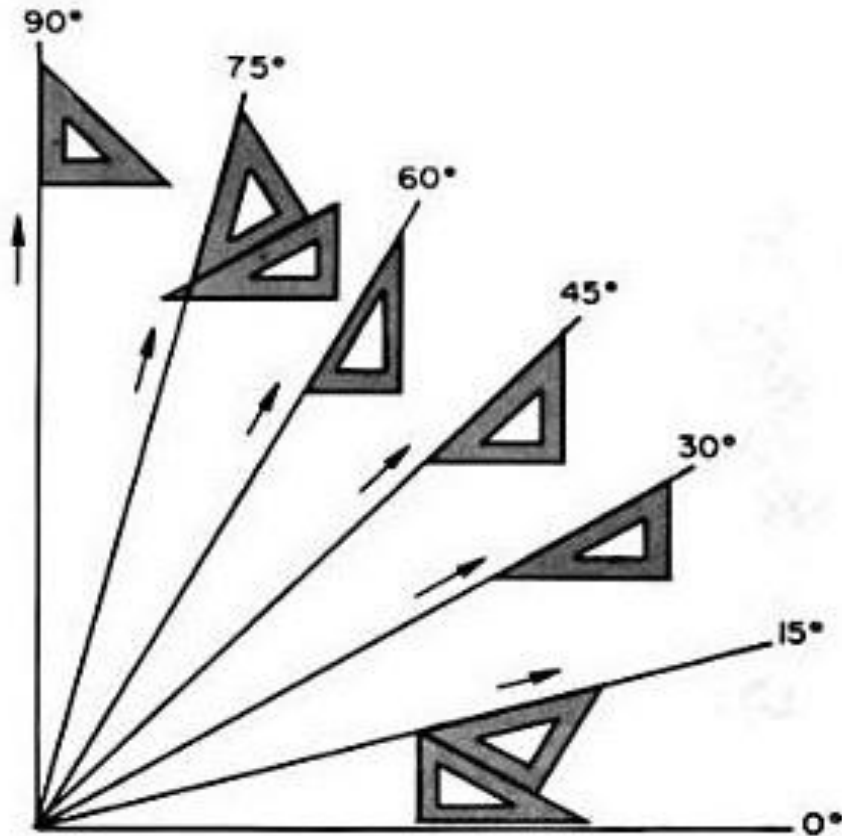

Figure 3-11. How to draw commonly used angles by combing the triangles.

Adjustable set squares are those which can be set at any angle..



Intro to technical drawing
set squares/triangles

technical drawing introduction

Tools used for technical drawings

Manual drafting tools

Compass and one divider



It is used principally in drafting for the accurate transfer of dimensions from a measuring scale.

Circles are drawn and portions of circles called arcs with an adjustable compass and calculation of angles from 1 degree to 180 degrees are done with clear plastic protractors.



Intro to technical drawing
compass/divider

technical drawing introduction

Tools used for technical drawings

Manual drafting tools

parallel bar



A parallel ruler is a **movable ruler** used on the drawing board. Its **angle stays constant** and with it the **horizontal lines** can easily be drawn all over the board. It is also used as a support for protractor and letter templates



Intro to technical drawing
parallel bar

technical drawing introduction

Tools used for technical drawings

Manual drafting tools

using a parallel bar



Intro to technical drawing
parallel bar

technical drawing introduction

Tools used for technical drawings

Manual drafting tools

architectural scale: **pay attention**



Architect's scale is a scaled, three-edged ruler which has six different scales marked to its sides.

technical drawing introduction

Tools used for technical drawings

Manual drafting tools

architectural scale: **pay attention**

Let's do a little work on reading your architect's scale. Your scale should never be used to draw lines it should only be used for measuring. Here is an example of what your scale would look like at $\frac{1}{4}$ " scale. If you drew a **4' line at $\frac{1}{4}$ " scale the line would actually be 1"** long because each foot is represented as a $\frac{1}{4}$ " length.

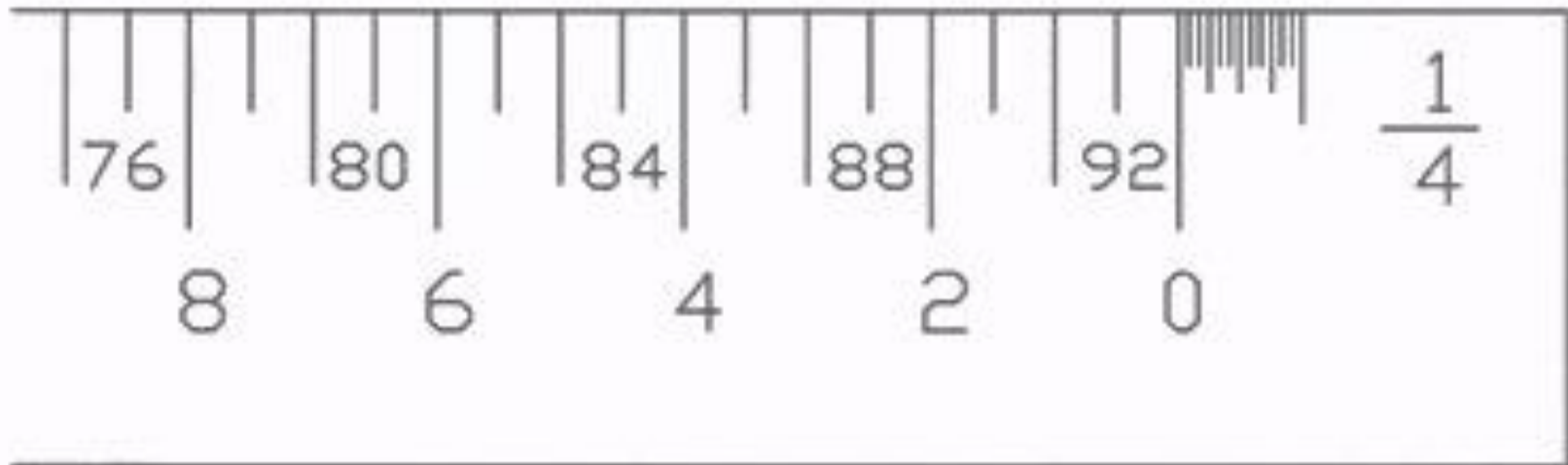

technical drawing introduction

Tools used for technical drawings

Manual drafting tools

architectural scale: **pay attention**

Let's go over a few things you should notice on your scale: Find the 0. To the left of the zero the inches are represented and to the right of the zero are feet. When you look at the inches you have to remember that there are 12" in a foot. When looking at the scale you should see that in the $\frac{1}{4}$ " scale the inches are divided in inch and half inch increments. Now looking to the right at the foot increments, you notice that there are two strings of numbers- one high and one low. *To figure out which numbers to read, look at the 0 and **read the numbers that are in line with the 0.***

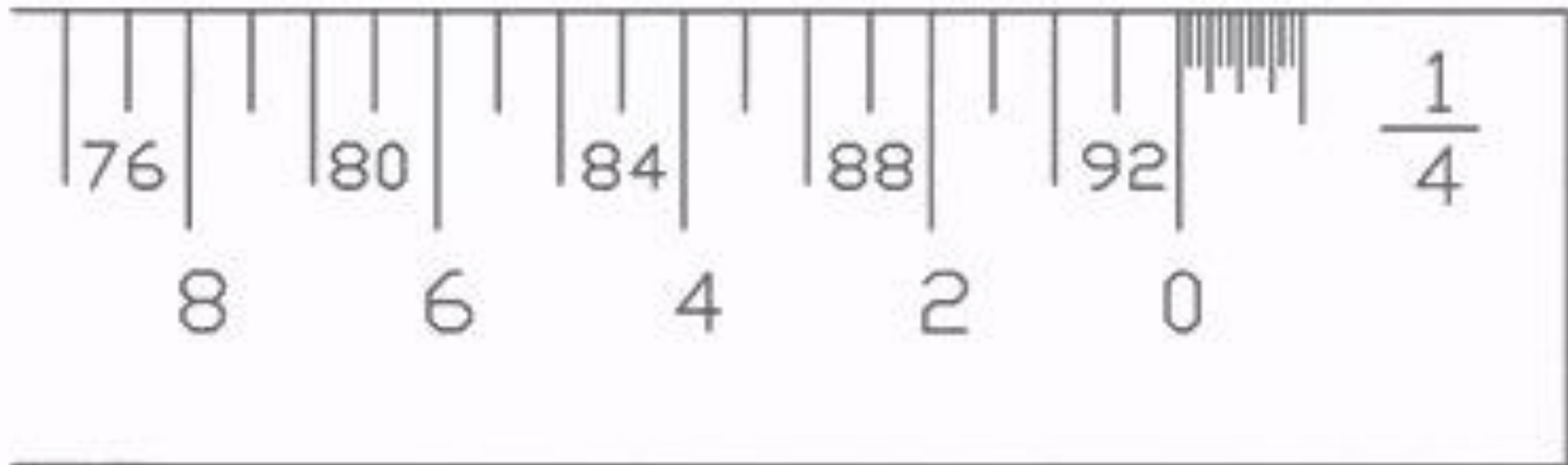

technical drawing introduction

Tools used for technical drawings

Manual drafting tools

reading an architectural scale

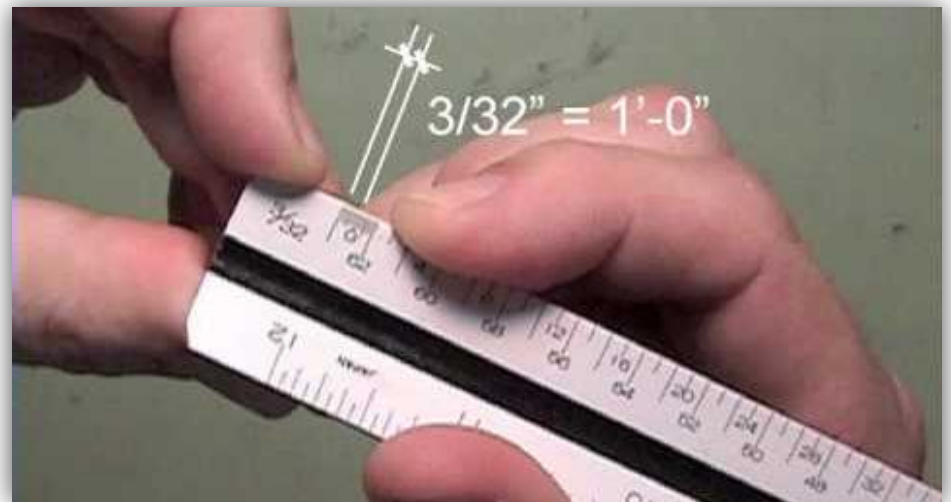
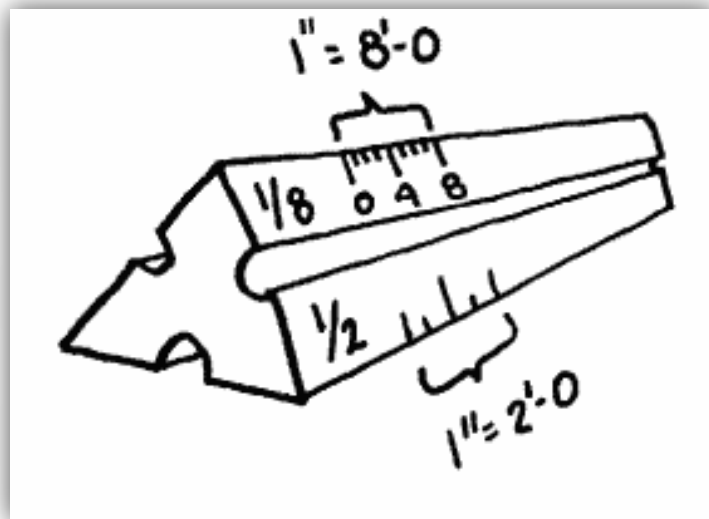

Intro to technical drawing
scale

technical drawing introduction

Tools used for technical drawings

Manual drafting tools

architectural scale: **pay attention**

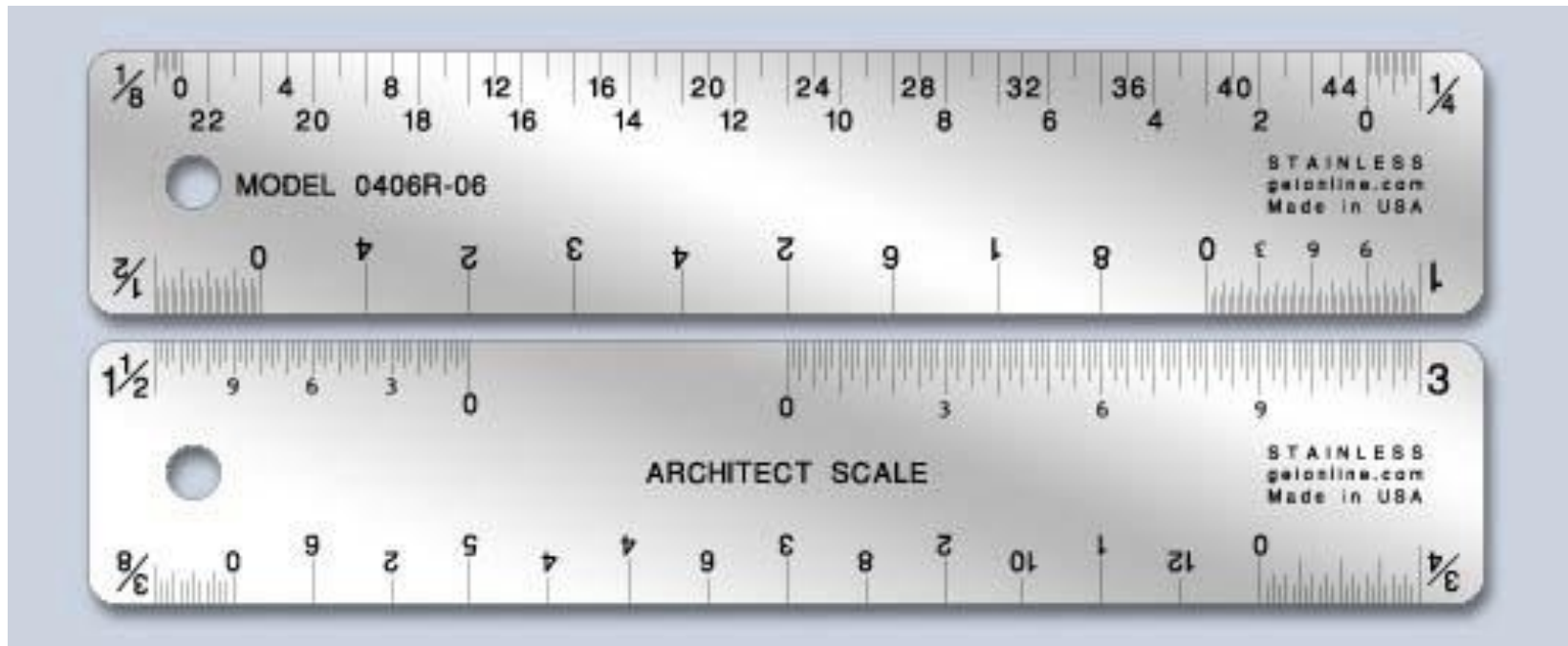

Architect's scale is a scaled, three-edged ruler which has six different scales marked to its sides.

technical drawing introduction

Tools used for technical drawings

Manual drafting tools

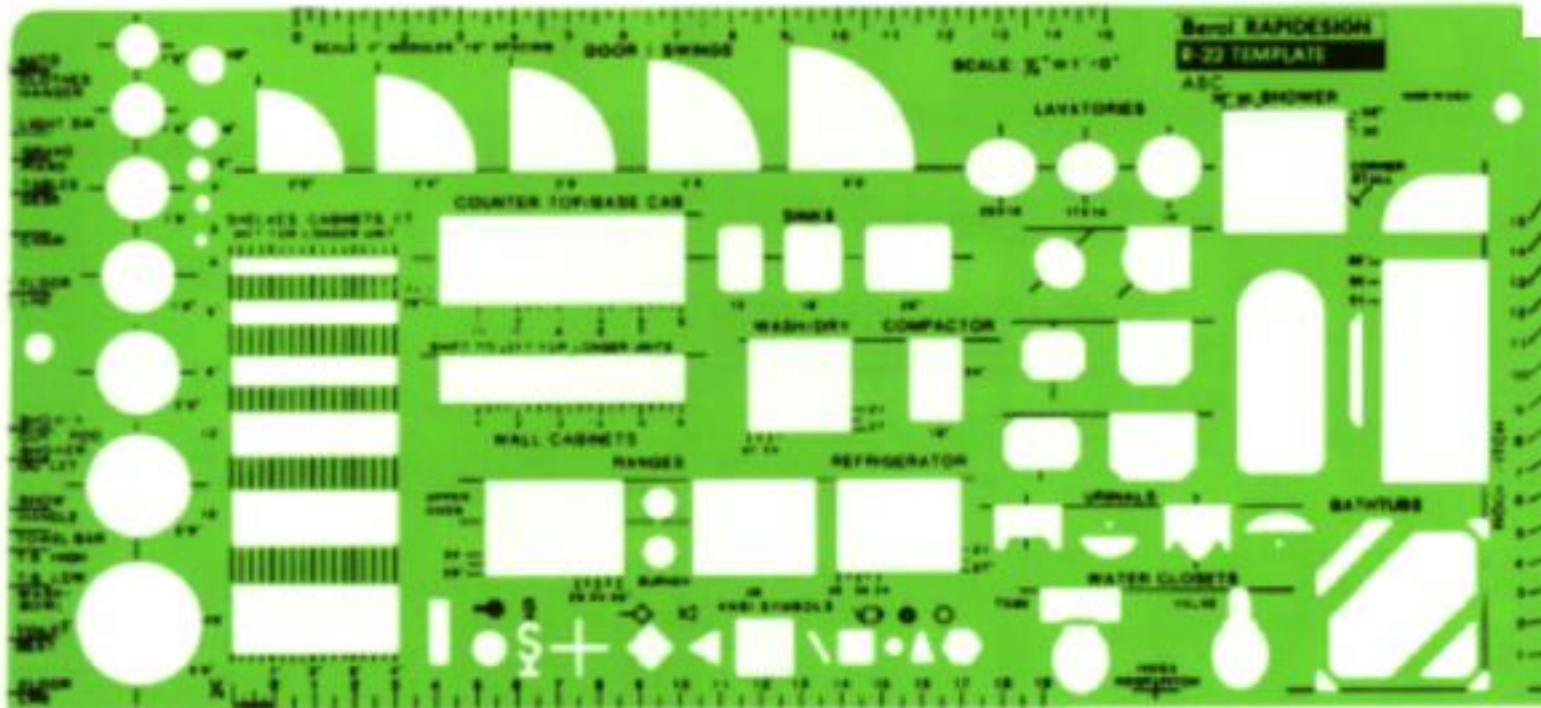

Intro to technical drawing
scale

technical drawing introduction

Axes used in technical drawings

axis

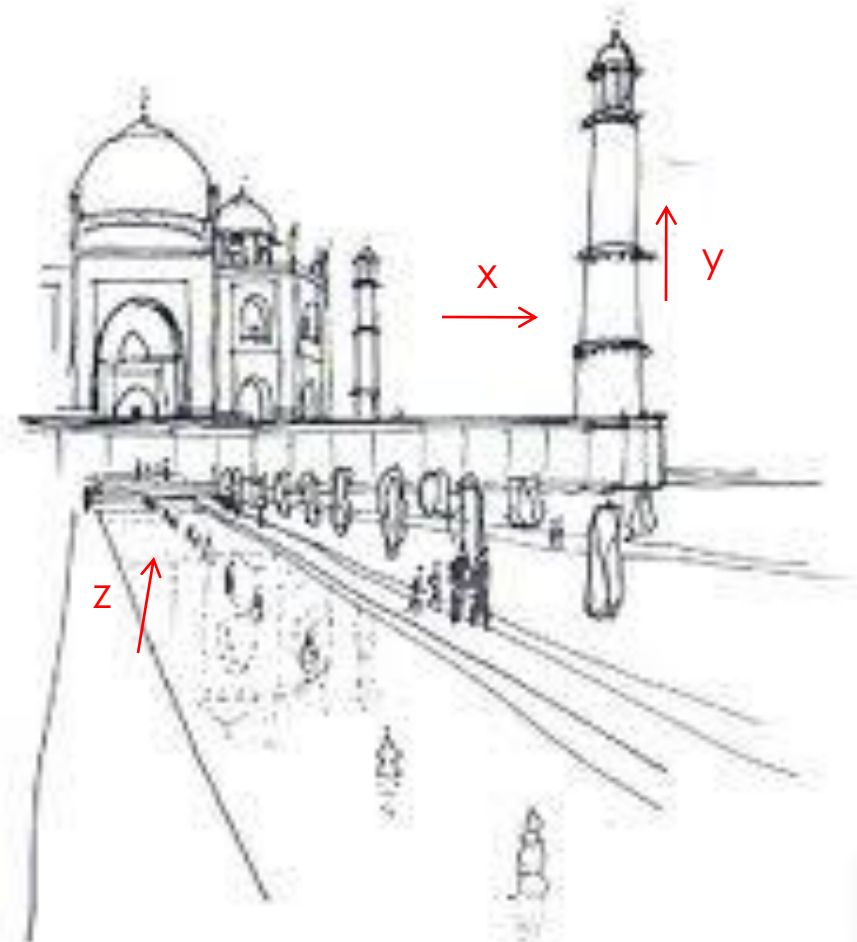

All architecture encapsulates space. Space is the whole of architecture. Architecture may be described by the same coordinates used to create any three-dimensional space: height, width and depth

In later stages, axis of time is also considered..



Intro to technical drawing
axis

technical drawing introduction

Axes used in technical drawings

axis

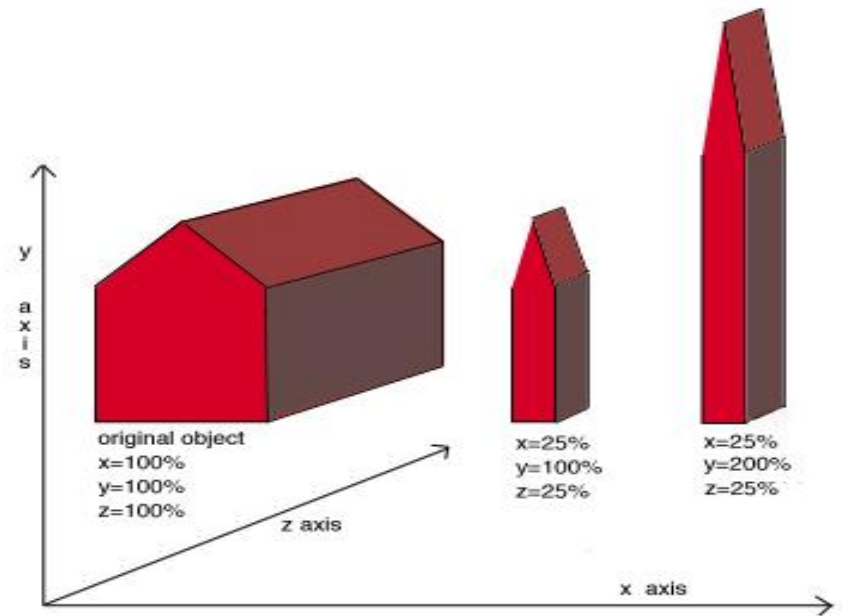
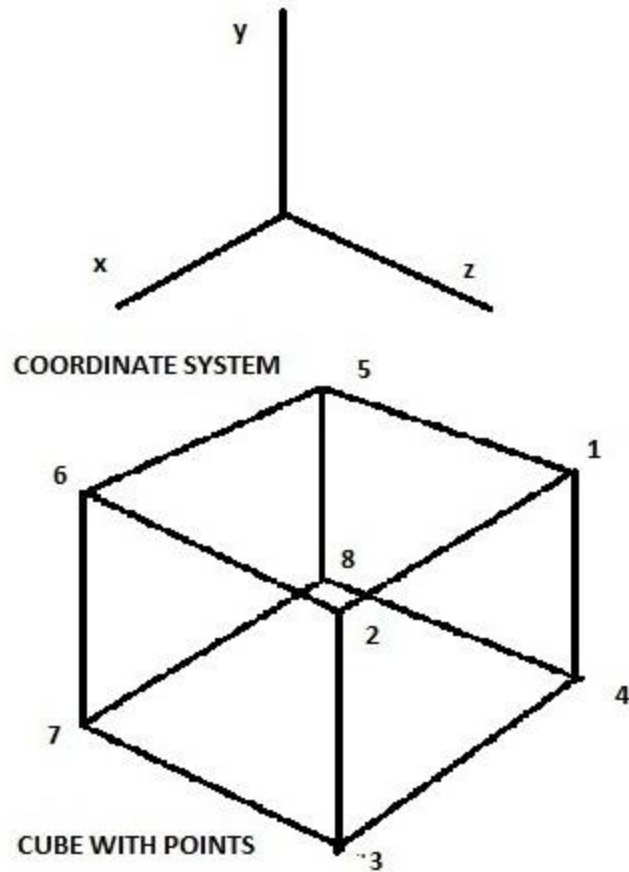

technical drawing introduction

orientation

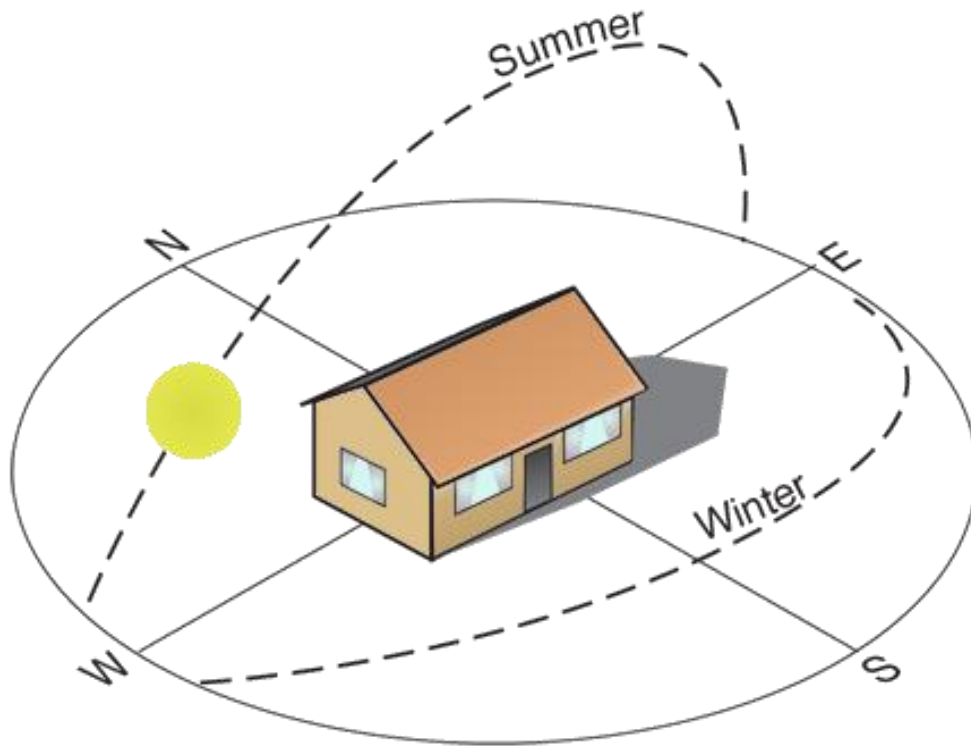

orientation, in architecture, the disposition of the parts of a building with reference to the **points of the compass**. north, south, east, west

It mainly depends on the **climate** of the area.

the Sun rises in the East and sets in the West

the Sun is higher in the Summer sky and lower in the Winter sky.



technical drawing introduction

orientation

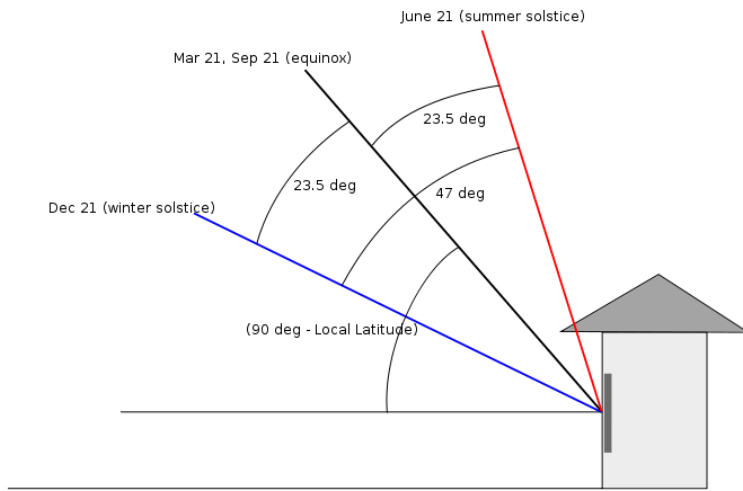

The fact the sun is lower in the sky in Winter than in Summer allows us to plan and construct buildings that capture that free heat in Winter and reject the heat in Summer.

It is very important that you remember to orientate your house with respect to the Sun and not to magnetic North

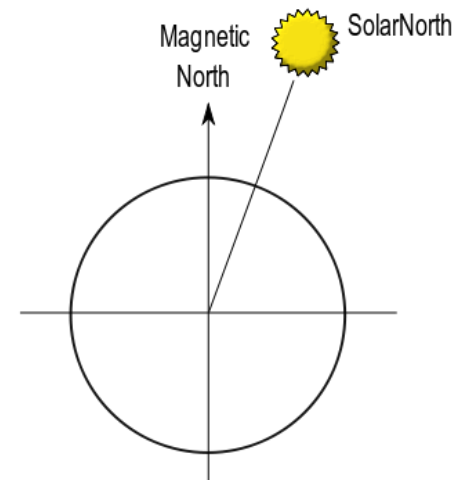

technical drawing introduction

Importance of context



Simulation of visual context in architecture, the **environment that surrounds both building and Observer** is called context.

Every building can and should **engage in a dialog** with the history, beliefs and needs of a particular place and time.



Intro to technical drawing
context

technical drawing introduction

Importance of context/ orientation in technical drawings

geographical context

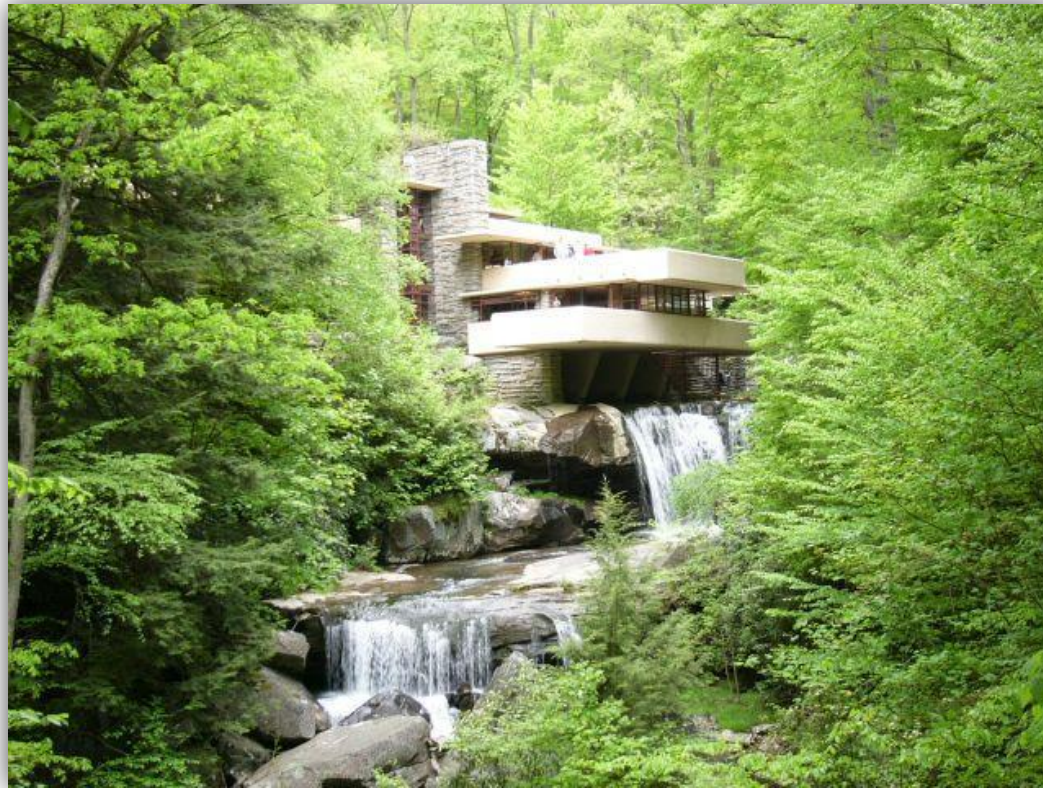

Intro to technical drawing
context- falling water

technical drawing introduction

Importance of context/ orientation in technical drawings

site context



Intro to technical drawing
drake circus shopping centre

technical drawing introduction

Importance of context/ orientation in technical drawings

cultural context



Intro to technical drawing
Louvre palace

technical drawing introduction

Parti diagram used for technical drawings

parti diagram

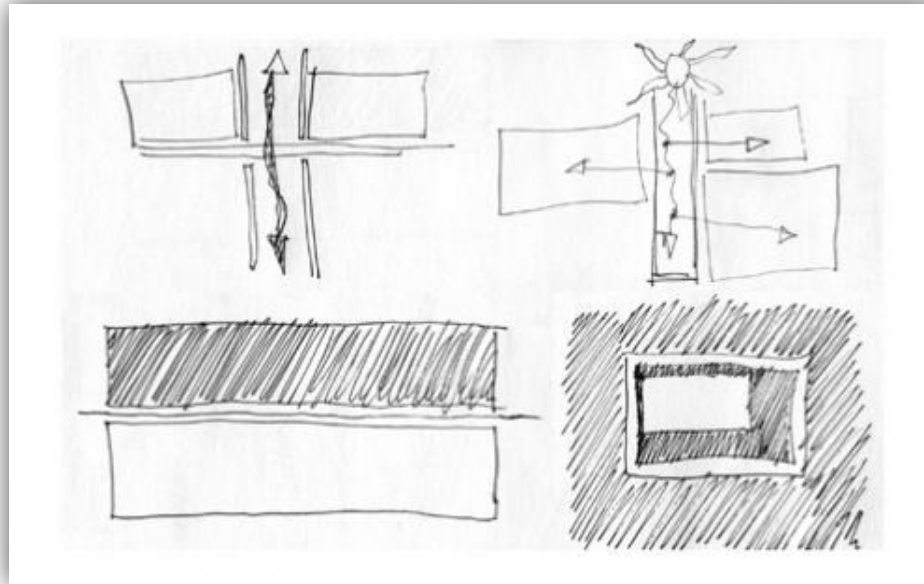

a parti diagram is **an idea sketch**, an initial response to a site, a client's program or some other conditions that begin to determine the order for designing a project. They don't really represent what the project will look like in plan or elevation.



technical drawing introduction

Parti diagram used for technical drawings

parti diagram

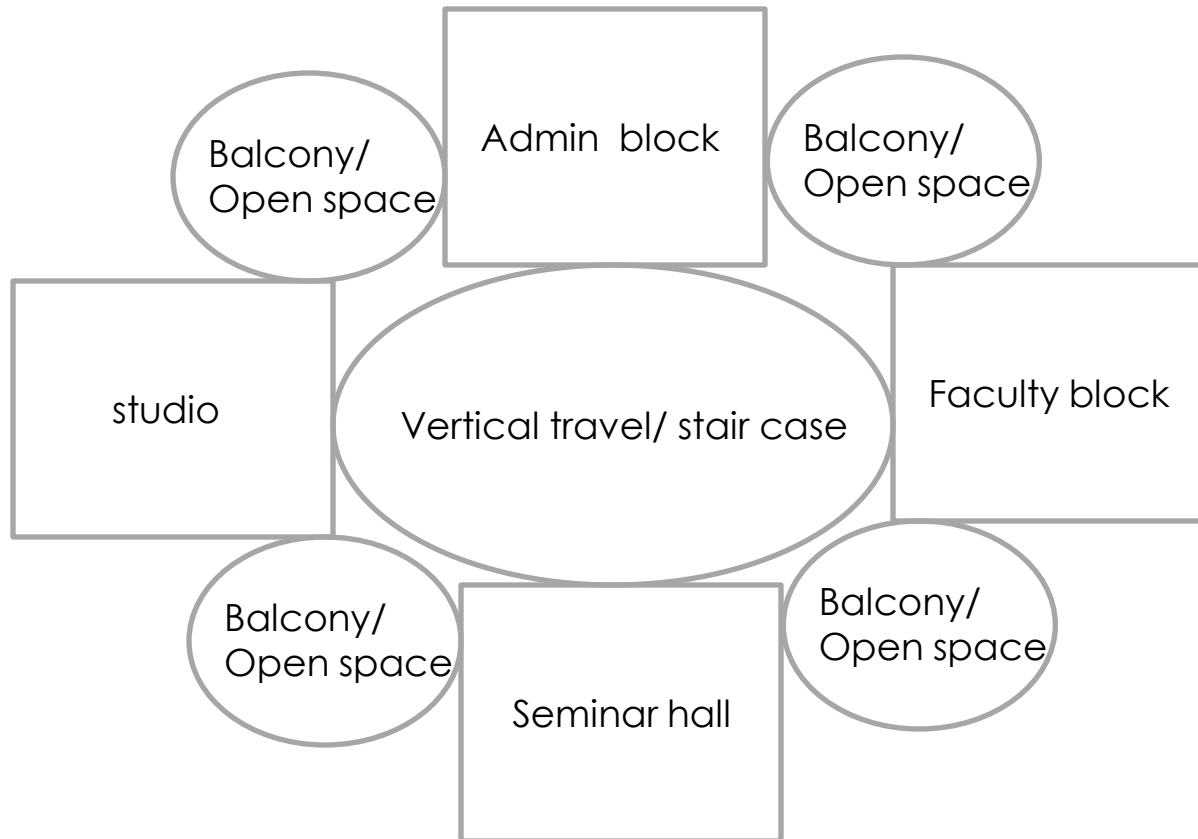

technical drawing introduction

Parti diagram used for technical drawings

parti diagram

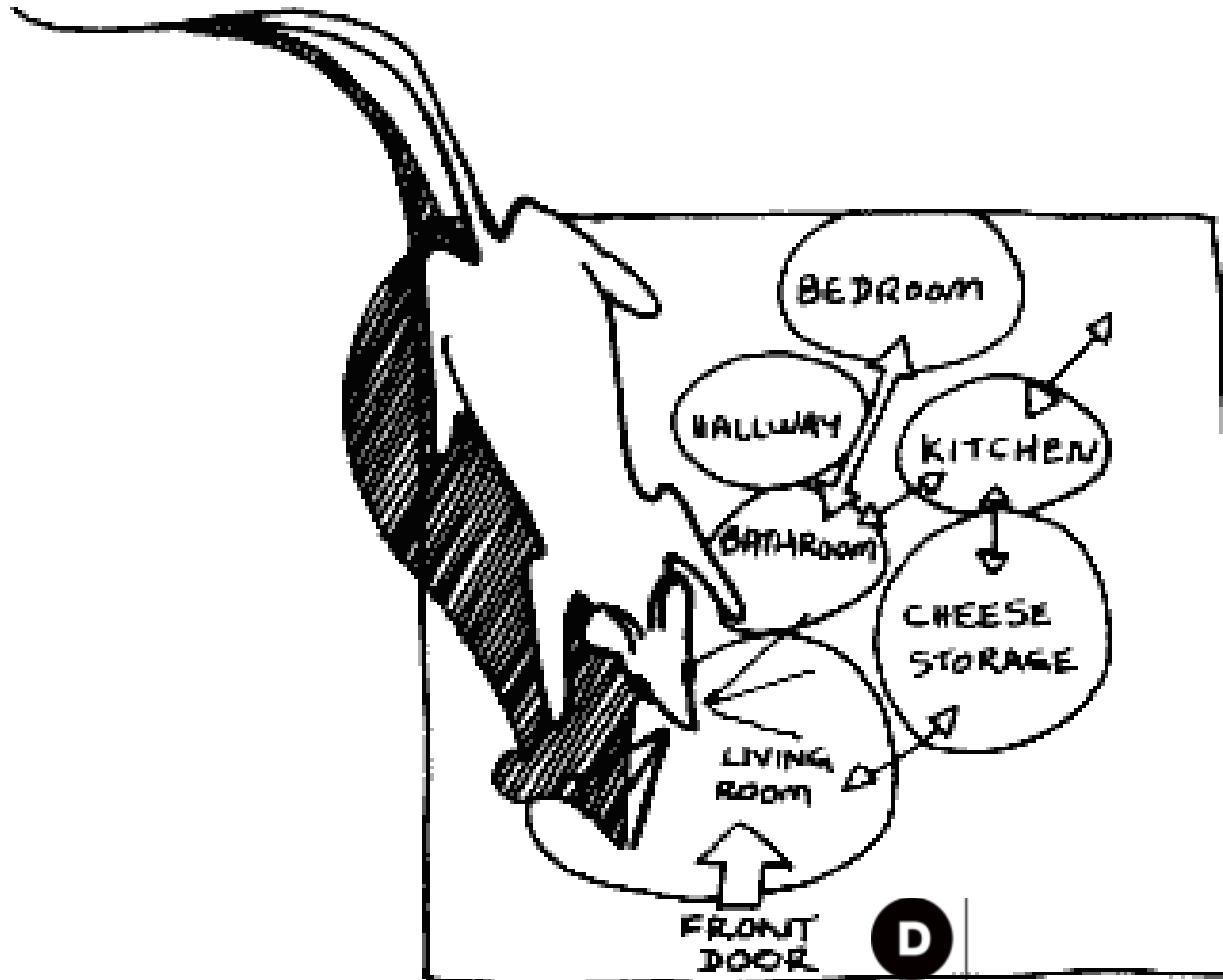

technical drawing introduction
end of the term submission

what is expected from you – 2 finished projects

1 - replication through repetition

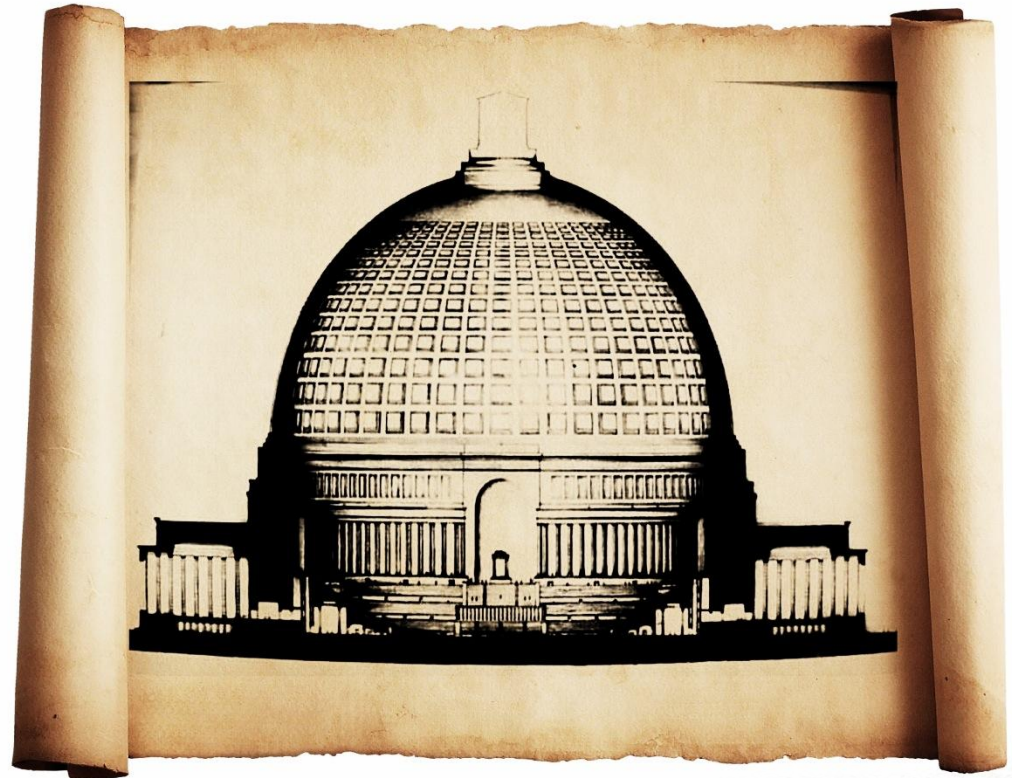

Intro to technical drawing
sada, spring 2010

technical drawing introduction

end of the term submission

what is expected from you – 2 outcomes

1 - replication through repetition

2 - a set of drawings including

- parti diagram
- plan
- site plan
- section
- site section
- elevations
- one of the 3d views of your choice



technical drawing introduction

examples of drawing boards

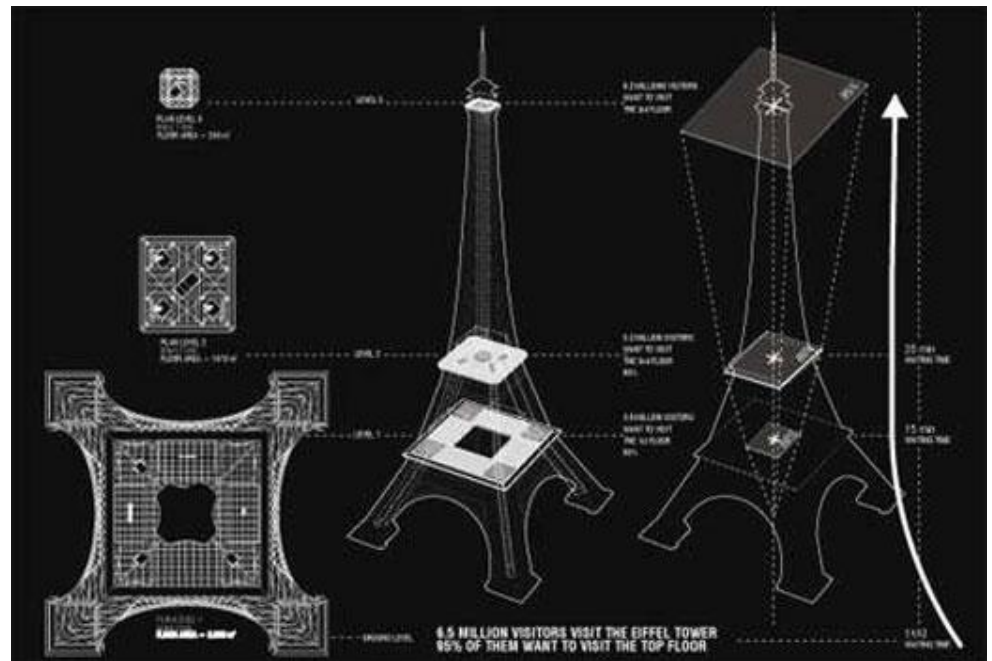
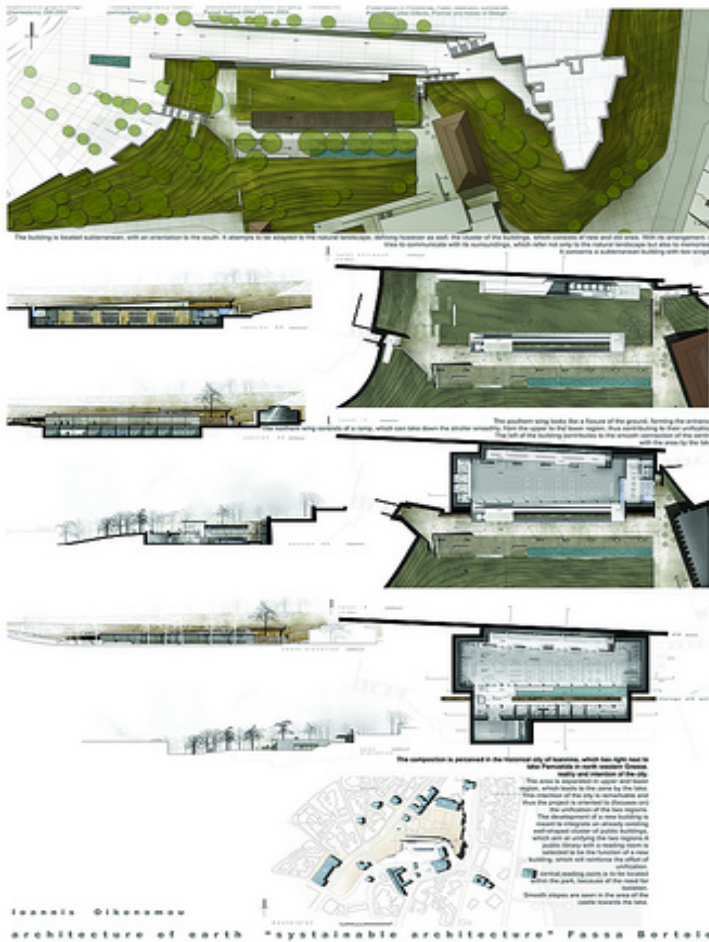

Intro to technical drawing
sada, spring 2010

technical drawing introduction

attention – assignment 1
draw a parti diagram

your place or mine?

Everyone wants to build a home for themselves. Imagine if you have the choice to choose any context and have the means to design your small house with one bed room, one living room, bath room and a kitchen.

- where will your house be? On a mountain or a beach or by the highway?
- what is the orientation? Where does the sun set?
- it has levels?
- is it going to be a conventional home ?
- what makes it unique and yours? do you see your personality in it?



attention – assignment 1

Your place or mine? Draw a parti diagram

PARTI DIAGRAMS.

COURTYARD.

VILLA SAVOYE

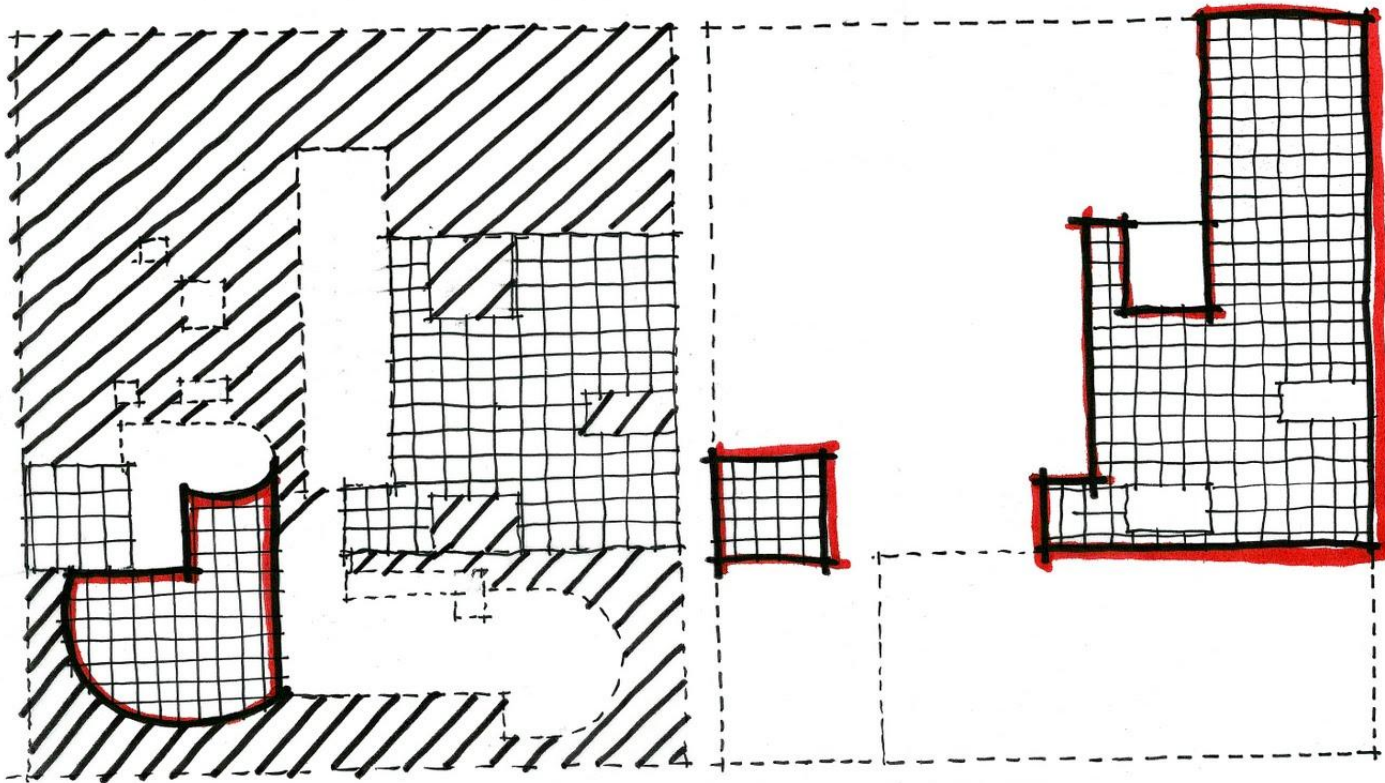

SUN PATIO.

FIRST FLOOR.

attention – assignment 1

Your place or mine? Draw a parti diagram

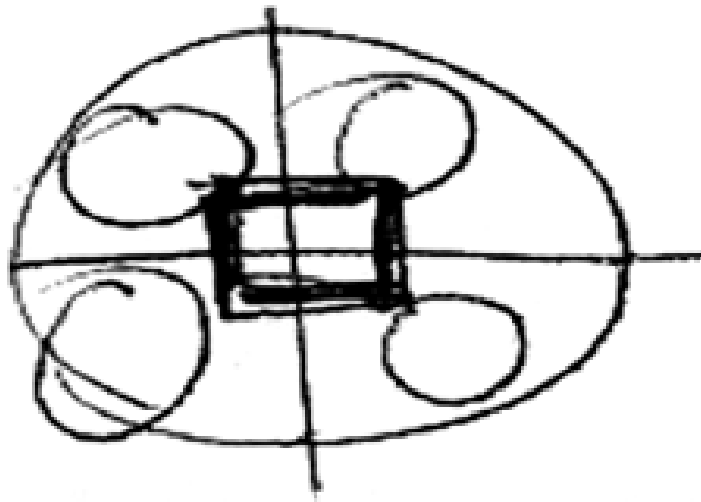

[a]

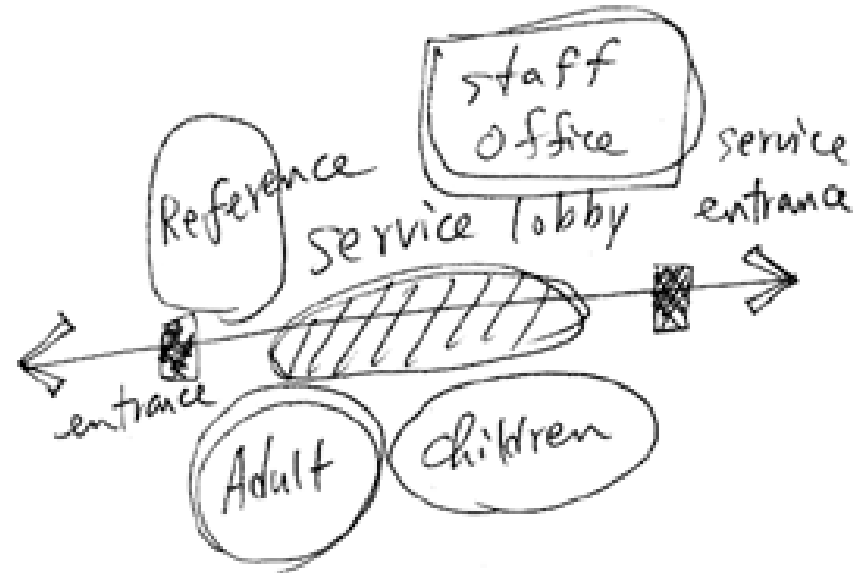

[b]

sketches are viewed as central to architectural design and serve as “reference” to be used, transformed, or engaged in a later composition (Graves 1977).



sada, spring 2010

attention – assignment 1

Your place or mine? Draw a parti diagram



sada, spring 2010

attention – assignment 1

Your place or mine? Draw a parti diagram



sada, spring 2010

attention – assignment 1

Your place or mine? Draw a parti diagram



sada, spring 2010

attention – assignment 1

Your place or mine? Draw a parti diagram



sada, spring 2010

attention – assignment 1

Your place or mine? Draw a parti diagram



sada, spring 2010

attention – assignment 1

Your place or mine? Draw a parti diagram

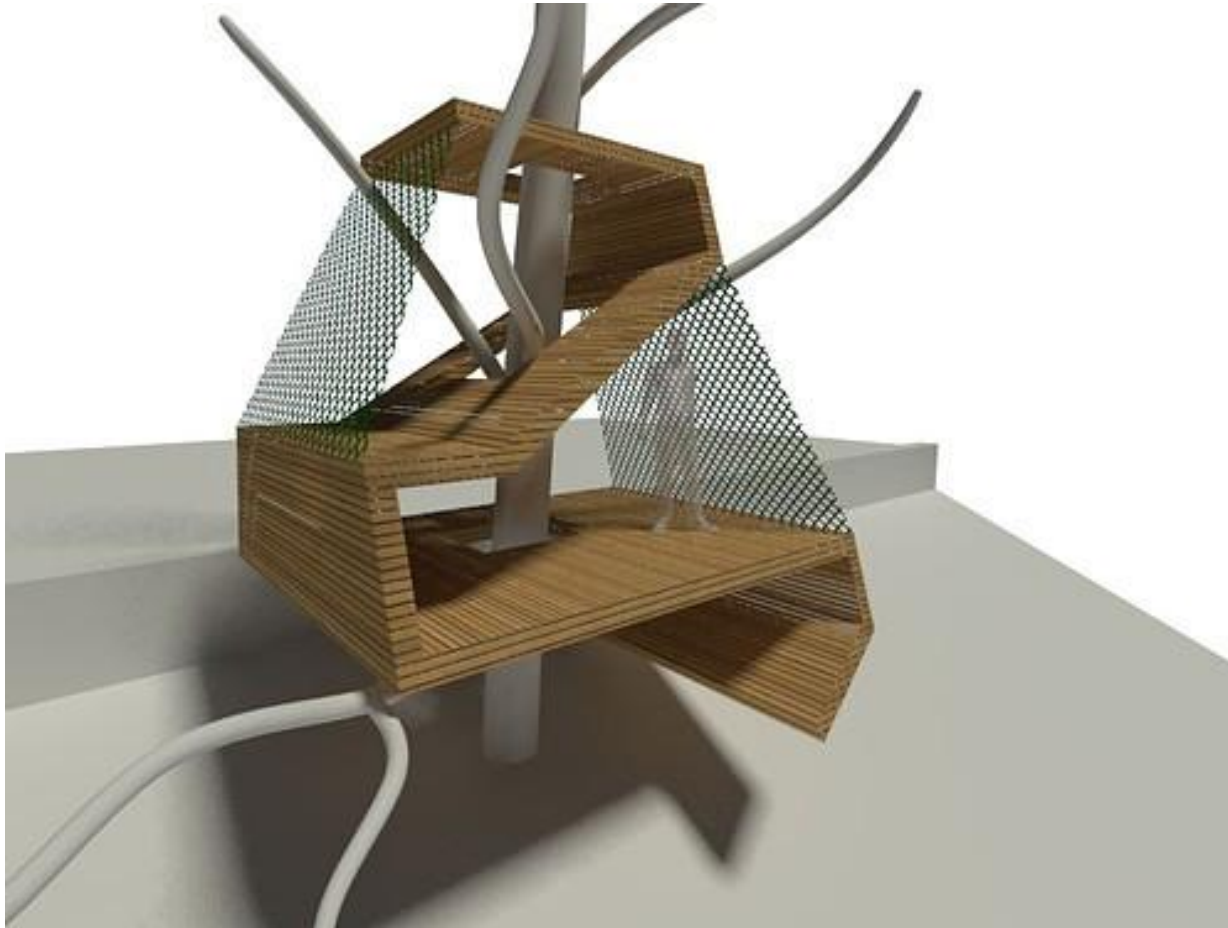

sada, spring 2010

attention – assignment 1

Your place or mine? Draw a parti diagram



sada, spring 2010

attention – assignment 1

Your place or mine? Draw a parti diagram



sada, spring 2010

attention – assignment 1

Your place or mine? Draw a parti diagram



sada, spring 2010

attention – assignment 1

Your place or mine? Draw a parti diagram



sada, spring 2010

BEFORE YOU
THINK OUTSIDE THE BOX
YOU NEED A BOX.



tools you **must** have in the next class

- Set squares (adjustable)
- Parallel bar
- T-square
- Architectural scale (triangular)
- Pencils (4H, 3H, 2H, H, HB, 1B, 2B, 3B, 4B)
- Drafting sheets size: 20" x 30" (available at sada)
- Compass
- Eraser
- Cutter/ sharpener
- Pen/pointer (at least 5 thickness : 0.2mm, 0.3mm, 0.4mm, 0.6mm)
(Snowman ink - smudge proof)
- Masking tape
- Stencils (interior lay out)

*All the tools should be graded in **inches**.*





D R A W I N G

a mean to design reasoning

UNITED STATES
DEPARTMENT OF THE INTERIOR
NATIONAL FIRE SERVICE
PLANNING & CONSULTATION DIVISION
NATIONAL CAPITAL AREA

technical drawing introduction
quote of the day

...AND THOSE WHO WERE SEEN DANCING
WERE THOUGHT TO BE INSANE BY THOSE
WHO COULD NOT HEAR THE MUSIC.

-FRIEDRICH NIETZSCHE



Intro to technical drawing
sada, spring 2010

technical drawing introduction
picture of the day



technical drawing introduction
building of the day



School of art, design and media, nanyang, singapore
CPG Consultants



Intro to technical drawing
sada, spring 2010

technical drawing introduction

video of the day

DESIGN PHILOSOPHY

A horizontal splash of water, captured in a high-speed shot, moving from left to right across the middle of the frame. The water is clear and blue, with many small droplets and bubbles trailing behind it. The background is a solid, light blue color.

[can you draw? part 1]

<http://www.youtube.com/watch?v=2Hw12xW5ZZ8>



Intro to technical drawing
sada, spring 2010