



## Material analyses of foam-based SiC FCI after dynamic testing in PbLi in MaPLE loop at UCLA



Maria Gonzalez<sup>a,\*</sup>, David Rapisarda<sup>a</sup>, Angel Ibarra<sup>a</sup>, Cyril Courtessole<sup>b</sup>, Sergey Smolentsev<sup>b</sup>, Mohamed Abdou<sup>b</sup>

<sup>a</sup> LNF-CIEMAT, Avda Complutense, 40, 28040 Madrid, Spain

<sup>b</sup> Fusion Science and Technology Center, UCLA, USA

### HIGHLIGHTS

- Samples from foam-based SiC FCI were analyzed by looking at their SEM microstructure and elemental composition.
- After finishing dynamic experiments in the flowing hot PbLi, the liquid metal ingress has been confirmed due to infiltration through local defects in the protective inner CVD layer.
- No direct evidences of corrosion/erosion were observed; these defects could be related to the manufacturing process.

### ARTICLE INFO

#### Article history:

Received 31 August 2015

Received in revised form 9 March 2016

Accepted 9 March 2016

Available online 1 April 2016

#### Keywords:

FCI development

Dual coolant lead lithium breeder blanket concept

DCLL

Silicon carbide

SiC

Material characterization

### ABSTRACT

Foam-based SiC flow channel inserts (FCIs) developed and manufactured by Ultramet, USA are currently under testing in the flowing hot lead-lithium (PbLi) alloy in the MaPLE loop at UCLA to address chemical/physical compatibility and to access the MHD pressure drop reduction. UCLA has finished the first experimental series, where a single uninterrupted long-term (~6500 h) test was performed on a 30-cm FCI segment in a magnetic field up to 1.8 T at the temperature of 300 °C and maximum flow velocities of ~15 cm/s. After finishing the experiments, the FCI sample was extracted from the host stainless steel duct and cut into slices. Few of them have been analyzed at CIEMAT as a part of the joint collaborative effort on the development of the DCLL blanket concept in the EU and the US. The initial inspection of the slices using optical microscopic analysis at UCLA showed significant PbLi ingress into the bulk FCI material that resulted in degradation of insulating properties of the FCI. Current material analyses at CIEMAT are based on advanced techniques, including characterization of FCI samples by FESEM to study PbLi ingress, imaging of cross sections, composition analysis by EDX and crack inspection. These analyses suggest that the ingress was caused by local defects in the protective inner CVD layer that might be originally present in the FCI or occurred during testing.

© 2016 Elsevier B.V. All rights reserved.

### 1. Introduction

The Dual Coolant Lead Lithium (DCLL) breeding blankets have been proposed for a DEMO reactor, where liquid lead-lithium alloy (PbLi) is used for power conversion and tritium breeding. A SiC-based Flow Channel Insert (FCI) is used to reduce the magneto-hydrodynamic (MHD) pressure drop from the flowing liquid and as a thermal insulator to separate the high-temperature PbLi (700 °C and higher) from the helium-cooled RAF/M steel structure [1].

The MHD flow facility MaPLE (Magneto-hydrodynamic PbLi Experiment) at UCLA, that utilizes molten PbLi alloy as working fluid, is a unique US facility that allows for testing the performance of FCIs under a magnetic field at working conditions relevant to the DCLL breeding blanket.

SiC is considered as a good candidate material for high temperature FCI applications. It is expected to provide both the required electrical and thermal insulation between high-temperature liquid PbLi and the structural RAF/M material. Electrical insulation mitigates the MHD pressure drop, which would otherwise result in intolerably high stresses in the structural walls.

The long-term objective of the collaboration between UCLA and CIEMAT is to support the development of designs and technologies linked to DCLL concept. The objective of the experiments per-

\* Corresponding author.

E-mail address: [maria.gonzalez@ciemat.es](mailto:maria.gonzalez@ciemat.es) (M. Gonzalez).

(a)



(b)

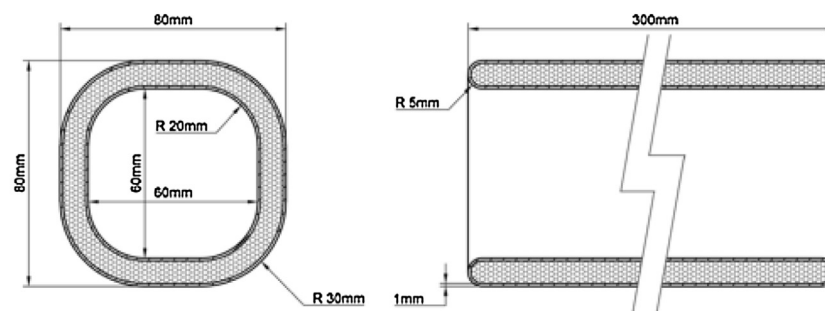

Fig. 1. Foam-based SiC FCI with CVD coating manufactured by Ultramet, USA: (a) a 30-cm FCI segment and (b) overall FCI segment dimensions.

formed at UCLA was to characterize the performance of foam-based CVD-coated SiC material in the conditions of the flowing PbLi in a magnetic field. The goal of the accompanying studies at CIEMAT, which are reported in this paper, was to conduct material analysis of the FCI segment used in the experiments.

## 2. Dynamic testing of FCI at UCLA and material characterization

### 2.1. Dynamic testing of FCI in MaPLE

The MHD PbLi flow loop at University of California, Los Angeles (UCLA) called MaPLE was constructed with the main objective of addressing PbLi behavior in blanket relevant conditions to take into account the effect of a magnetic field [2]. The loop operation parameters are: maximum magnetic field 1.8 T, PbLi temperature up to 350 °C, maximum PbLi flow rate with/without a magnetic field 15/50 l/min, maximum pressure head 0.15 MPa.

A MHD pressure drop in recent experiments on testing a foam-based SiC FCI was measured in PbLi flows in a host stainless steel rectangular duct where the FCI was inserted. The FCI fabricated by Ultramet, Inc. has a square shape with rounded corners. It is sealed on both inner and outer surfaces with dense SiC facesheets to protect from PbLi ingress (Fig. 1). As an additional protection means, the bulk 85% porosity material is filled with silica aerogel. The pressure drop was measured over the bare duct section (without the FCI) and over the 30 cm FCI segment simultaneously, using an indirect pressure measurement technique described in [2]. The magnetic field in the experiment was varied from zero

to 1.8 T (Hartmann number up to 1500) and the velocity up to ~15 cm/s (Reynolds numbers above 5000). The uninterrupted test of the FCI took approximately 6500 h. Further details describing the loop and the experiments could be found elsewhere [3]. Surprisingly, the experiments at UCLA did not demonstrate anticipated reduction of the MHD pressure drop, which could be explained by PbLi ingress causing degradation of FCI electrical insulation. As a matter of fact, weight analysis, visual inspection and preliminary microscopic analysis at UCLA all confirmed significant PbLi ingress equivalent to about 45% of the total FCI volume.

### 2.2. Post-testing material characterization

Several samples were produced from the FCI segment used in the experiments at UCLA with a diamond saw, from the inlet, middle and outlet sections of the FCI box. These samples were analyzed at CIEMAT for cracking and other possible defects, internal microstructure and elemental composition to figure out possible causes of the ingress. As a first approach, a Nikon optical microscope was used. After further cutting and mirror-like diamond polishing, samples were C-coated to avoid surface charging due to the electron beam. A Zeiss Auriga Compact scanning electron microscope (FESEM+FIB) and a Bruker Xflash EDX detector were applied for imaging and chemical analysis. All FESEM images presented here in Figs. 2, 3 and 5 show the background in black, the SiC and the filler phases in grey and the solidified PbLi in bright white. Few samples were also FESEM studied as-fractured from the as-received condition.

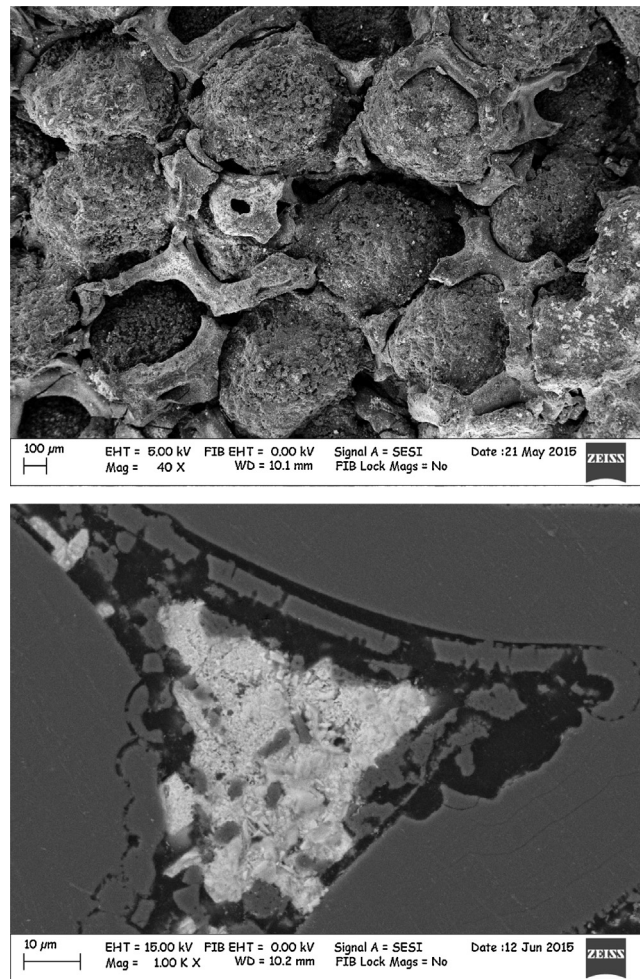

**Fig. 2.** Fresh fracture FESEM image taken from the inlet section of the SiC FCI tube showing the FCI foam filled (top). PbLi was also detected filling the core of the SiC ligaments (bottom).

### 3. Results and discussion

Heavy PbLi ingress was observed to occur during testing in the flowing liquid in a fresh fractured FESEM image (Fig. 2, top). Elemental lead was detected both filling the pores and also the core of the SiC ligament structure itself, as seen in the magnified SEM image (Fig. 2, bottom). The EDX mappings or line profile analyses show the purity of SiC fibers, the presence of Si-based granules inside the pores of the 3D foam structure, together with the ingress of PbLi (Fig. 3).

The samples taken from the FCI inlet section demonstrate more ingress compared to those samples taken from the middle and outlet sections, which show about the same ingress. A measurement of the center of mass location showed that it coincided with the geometrical center of the FCI. This suggests a uniform ingress over the entire FCI length. The post-testing examination also indicates an occasional lack of the facesheet material mainly in the inlet sample, which could be due to manufacturing flaws or might occur in the course of testing since the experiment took an unusual long time. However, since testing was not interrupted for examination of the FCI, the reason for defects in the CVD layer is not completely understood at this moment. Furthermore, the inner facesheet was found to be thinner and at some locations was completely absent, while the outer CVD layer almost did not change its nominal thickness of about 1 mm. The defects in the inner CVD coating should be then considered as the most possible way of PbLi ingress into the foam structure. Since previous immersion tests in static molten PbLi

on uncoated SiC samples also manufactured by Ultramet exhibited minimal metal ingress at 700 °C [3], the explanation for the observed ingress in dynamic tests could be related to the flow effects. Moreover, in the dynamic tests the FCI sample was exposed to PbLi over a very long period of about 6500 h while static tests took only 100 h.

Highly cracked samples were found when studying the microstructure; the cracks have been observed to run through both the SiC dense coatings and also through the foam SiC structure. Cracking in the FCI appeared visually in a couple of weeks after it was extracted from the liquid metal loop, possibly due to the exposure of the FCI to the air and atmospheric moisture. A few larger cracks also formed when the FCI segment was being sawed into slices. All cracks, large and microscopic, were not filled with PbLi suggesting that no crack formation occurred during the experiment.

No difference in the PbLi ingress between the Hartmann and the side walls (nomenclature given to the FCI walls located perpendicular and parallel to the magnetic field, respectively) was found as seen from the micrographs. This clearly demonstrates that there is no effect of the magnetic field direction on the PbLi transport into the FCI bulk material and also on corrosion/erosion of the protective CVD layer. Nevertheless, the solidified metallic phase seems to be more concentrated in regions next to the CVD coating. In particular, more ingress was found near the outer FCI surface compared to the inner surface. Fig. 4 shows the plot of the PbLi-to-SiC phase balance obtained with the ImageJ free software applied to a number of

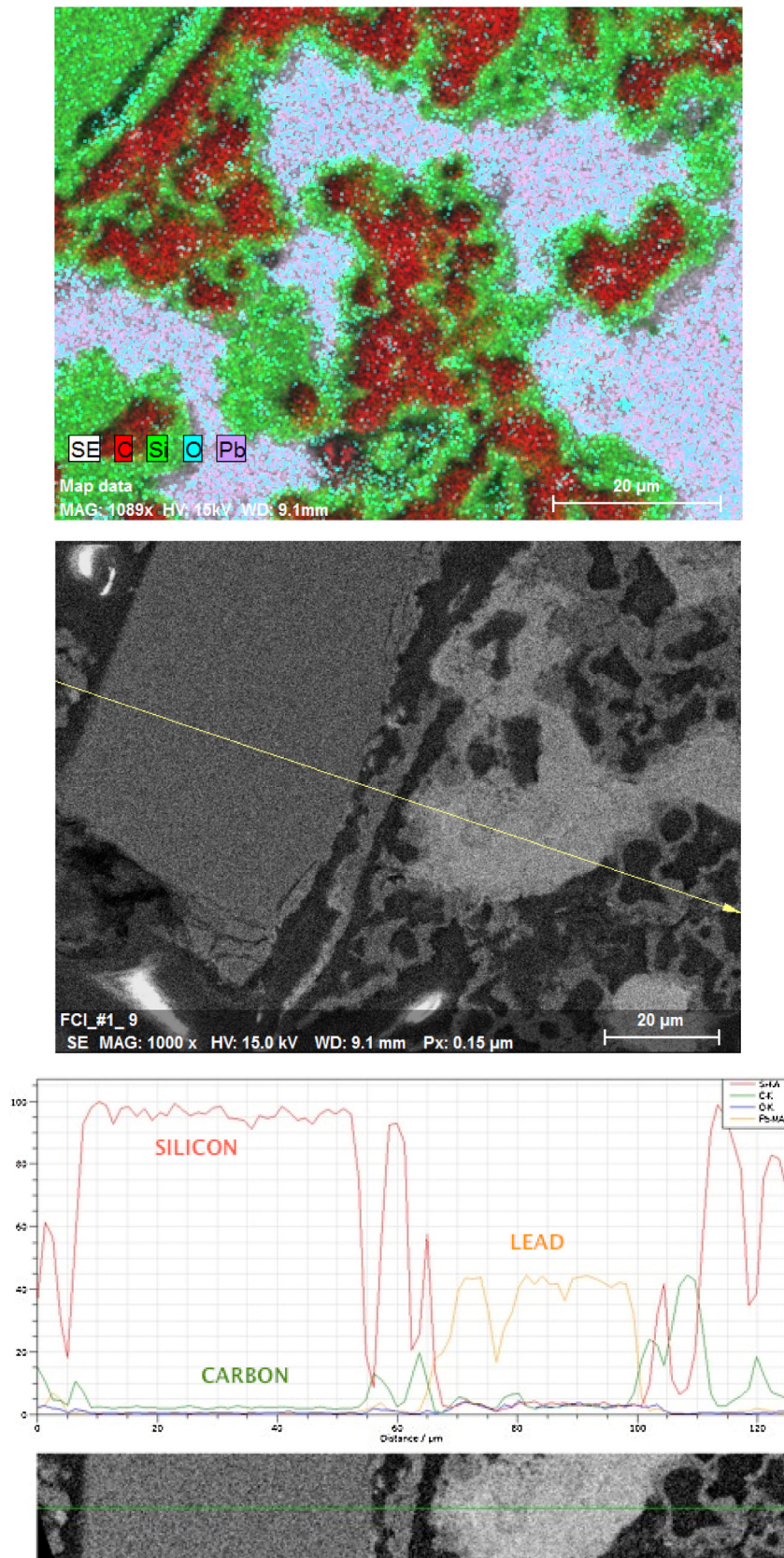

**Fig. 3.** EDX mapping showing the elemental composition of a FCI cross-section sample (top figure). The analytical line profile (bottom figure) crosses the SiC foam structure into the infiltrated pores also filled with solidified PbLi.

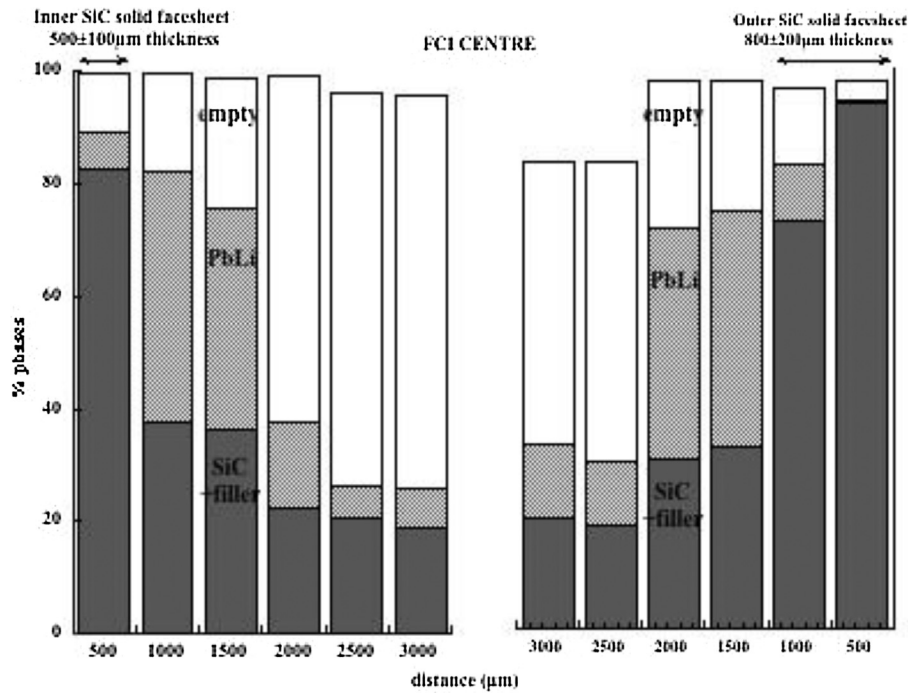

Fig. 4. Local distribution of the solid phases across the FCI wall (from the inner to the outer facesheet) after the MHD experiment in PbLi. “Empty” refers to the remaining empty space in the foam pores. The measurement errors mostly appear when calculating the empty space.

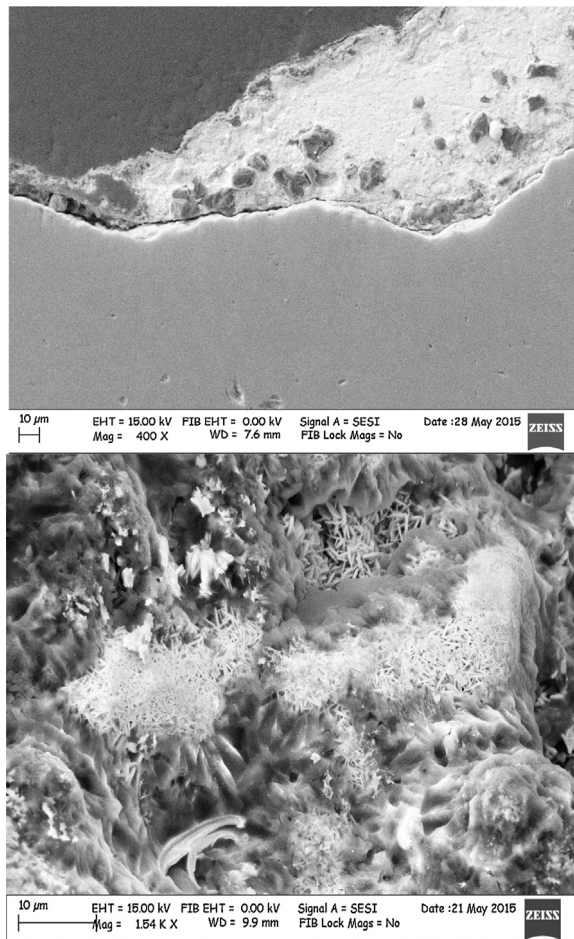

Fig. 5. Top) PbLi or lead oxide particle adhered to the inner FCI coating showing no SiC surface modification. Left) needle-like PbLi particle decorating the surface of an internal SiC foam ligament.

average images taken from the outlet section. The reason for higher PbLi concentration near the CVD layers is not clear but it could be related to the radial temperature gradient during the FCI segment cooling after extracting the FCI from the host duct. The rather low volume of solidified PbLi may generate a pressure gradient, which could favor the liquid solidification near the dense SiC.

Magnified images suggest that no damage occur to both the surface of the SiC facesheets and the foam constituents in the flowing PbLi run (Fig. 5). Furthermore, the EDX line profiles indicate no lead diffusion into the SiC phase and the absence of oxygen, nitrogen, as common impurities that could be introduced during the experiment. This suggests good chemical compatibility between PbLi and dense SiC, at least in the experimental conditions. Therefore, the observed thinning of the inner CVD layer is likely related to the manufacturing process rather than corrosion/erosion. Solidified PbLi and metal oxide particles showing different geometries (rounded drops, needle- or platelet-like particles, see also Fig. 5) have been found adhered rarely to the surfaces of the foam ligaments and to the dense SiC facesheets. Oxidation of PbLi probably occurred along with the development of cracks.

#### 4. Conclusions

After finishing dynamic experiments in the flowing hot PbLi, samples from the inlet, middle and outlet sections of the SiC-coated, foam-based SiC FCI infiltrated with silica aerogel were analyzed by looking at their SEM microstructure and elemental composition.

These analyses confirmed heavy PbLi ingress that could be explained by liquid metal infiltration through local defects in the protective CVD layer. Most likely most of the infiltration occurred through the inner CVD facesheet, which was found to be much

thinner than the outer one. Since no direct evidences of corrosion/erosion were observed, these defects could be related to the manufacturing process. If so, next efforts on development and fabrication of coated SiC FCIs should focus more on protective layers that guarantee no liquid metal ingress over a long run.

#### Acknowledgments

This study was performed as a part of the collaborative agreement between UCLA and CIEMAT on the development of the DCLL blanket concept in the EU and the US. The material analyses reported in this paper have been carried out within the framework of the EUROfusion Consortium and have received funding from the Euratom research and training program 2014–2018 under grant agreement No 633053. The views and opinions expressed herein do not necessarily reflect those of the European Commission. The microstructural study was performed using instrumentation partially funded with the European Regional Development Fund (FEDER-ICTS-2011-06). The US authors acknowledge support from the US Department of Energy, Office of Fusion Energy Sciences, under Grant No. DE-FG02-86ER52123.

#### References

- [1] S. Malang, M. Tillack, C.P.C. Wong, N. Morley, S. Smolentsev, Development of the lead lithium (DCLL) blanket concept, *Fusion Sci. Technol.* 60 (2011) 249–256.
- [2] S. Smolentsev, F.-C. Li, N. Morley, Y. Ueki, M. Abdou, T. Sketchley, Construction and initial operation of MHD PbLi facility at UCLA, *Fusion Eng. Des.* 88 (2013) 317–326.
- [3] S. Smolentsev, C. Courtessole, M. Abdou, S. Sharafat, S. Sahu, T. Sketchley, First results of static and dynamic testing of foam-based SiC flow channel insert in lead-lithium, *J. Nuclear Mater.* (2015).