

GA-A22728

**THE LOW ASPECT RATIO DESIGN CONCEPT —  
POSSIBILITY OF AN ACCEPTABLE FUSION  
POWER SYSTEM**

by  
**C.P.C. WONG, R. CERBONE, E.T. CHENG, R.L. MILLER,  
and R.D. STAMBAUGH**

**DECEMBER 1997**

## DISCLAIMER

This report was prepared as an account of work sponsored by an agency of the United States Government. Neither the United States Government nor any agency thereof, nor any of their employees, makes any warranty, express or implied, or assumes any legal liability or responsibility for the accuracy, completeness, or usefulness of any information, apparatus, produce, or process disclosed, or represents that its use would not infringe privately owned rights. Reference herein to any specific commercial product, process, or service by trade name, trademark, manufacturer, or otherwise, does not necessarily constitute or imply its endorsement, recommendation, or favoring by the United States Government or any agency thereof. The views and opinions of authors expressed herein do not necessarily state or reflect those of the United States Government or any agency thereof.

# THE LOW ASPECT RATIO DESIGN CONCEPT — POSSIBILITY OF AN ACCEPTABLE FUSION POWER SYSTEM

by  
C.P.C. WONG, R. CERBONE,<sup>†</sup> E.T. CHENG,<sup>†</sup> R.L. MILLER,  
and R.D. STAMBAUGH

<sup>†</sup>TSI Research

This is a preprint of a paper to be presented at the 17th IEEE/NPSS  
Symposium on Fusion Engineering, October 6–11, 1997, San Diego,  
California and to be published in the *Proceedings*.

Work supported by  
General Atomics IR&D and TSI Research under the Department of  
Energy, SBIR Program

GA PROJECT 4437  
DECEMBER 1997

# The Low Aspect Ratio Design Concept — Possibility of an Acceptable Fusion Power System\*

C.P.C. Wong,<sup>a</sup> R. Cerbone,<sup>b</sup> E.T. Cheng,<sup>b</sup> R.L. Miller,<sup>a</sup>  
and R.D. Stambaugh<sup>a</sup>

<sup>a</sup>General Atomics, P.O. Box 85608, San Diego, California 92186-9784

<sup>b</sup>TSI Research, Solana Beach, California 92075

**Abstract** — A scoping design code has been prepared and utilized to evaluate the critical issues of the Low Aspect Ratio (LAR) Concept as a design for a fusion power reactor. The physics basis for the  $A=1.4$ ,  $\kappa=3$ ,  $\beta_T$  of 62% and bootstrap fraction of 87% equilibrium design point was derived from earlier work. Using Krypton to enhance the radiation from the core, it is shown to be possible to trade off the heat flux between the first wall and the divertor, with corresponding reduction in fusion power. An aggressive technology approach is used to push critical components toward respective design limits. To minimize the reactor size, no inboard shielding of the Cu-alloy TF-coil central column is used. A helium-cooled, V-alloy, LiPb breeder first wall and blanket design that can withstand high heat flux and neutron wall loading is proposed. With this combination of materials and design, the major radius of a 1998 MWe reactor can be as small as 2.9 m. The material fluence lifetime of 15 MW.y/m<sup>2</sup> is assumed for both Cu and V-alloys. Including the change out cost of the Cu-alloy central column and outboard first wall and blanket during the reactor lifetime of 30 years, the cost of electricity is estimated to be 52.9 mill/kWhr. The total direct cost is \$5.3B. This is significant, because at \$2650/We fusion begins to approach a manageable development cost, supporting the motivation of adopting the LAR development path for the achievement of economic fusion power.

## INTRODUCTION

The LAR confinement concept, because of its potential for high toroidal beta ( $\beta_T$ ) and bootstrap fraction, has the possibility of operating at high plasma power density and low current drive power. Accordingly, the LAR concept has received a lot of interest for many years [1]. Near term proof of principle experiments, MAST and NSTX [2,3], are being constructed in England and the U.S. It has also been suggested that a relatively low cost normal coil pilot plant has some clear advantages over a traditional superconducting tokamak as an important step in the development of magnetic confinement fusion [4]. When compared to the more conventional aspect ratio, superconducting tokamak reactor design [5], higher plasma power density means that for the same electrical power output, the reactor can be smaller. A compact high power density design provides many design challenges,

both physics and technology based. In this paper we will focus on those technology issues associated with high neutron wall loading and high power flux to the first wall. For normal conducting coil designs with small coil current, a smaller device means lower recirculating power. However, higher plasma power density also means that the first wall, blanket and divertor components will have to handle higher power densities. A helium-cooled, V-alloy, first wall blanket design is proposed. An innovative approach of core radiation is also introduced to distribute the transport power to the first wall and to alleviate the maximum heat flux burden to the divertor. Higher core impurity content would also lead to lower plasma performance and fusion power output. For system evaluation, a scoping design code is used to evaluate the trade-off of these physics and technology concepts based on respective component design criteria and requirements. To generate an understanding on the performance potential of the LAR reactor, designs were evaluated at high average neutron wall loading approaching 8 MW/m<sup>2</sup>, TF-coil central column coolant velocity approaching 10 m/s, and a material neutron fluence life of 15 MW.y/m<sup>2</sup>. The system costs of the reference 1998 MWe design are presented. Technology critical issues and research and development needs for the LAR concept are also identified.

## PHYSICS

The physics basis for the  $\beta_T$  of 62%, aspect ratio  $A=1.4$ , elongation  $\kappa=3$ , and bootstrap fraction of 87% equilibrium design point was derived from the formalism of [4]. With a given TF-coil central column current density and geometry, the TF-coil current can be determined. With the plasma density and temperature profiles, and central ion temperature of 25 keV as inputs, the ion density,  $n_{DT}$  can be calculated. Accordingly, the alpha power,  $P_\alpha$  can be determined by,

$$P_\alpha = 2.8 \times 10^{15} P_{vol} \int_0^1 n_{DT}^2 \langle \sigma v \rangle x dx \quad (1)$$

where,  $P_{vol}$  is the plasma volume in m<sup>3</sup>,  $x$  is the normalized radius, and the reactivity term,  $\langle \sigma v \rangle$ , is given by the formulation of [6].

With (1) and the given reactor geometry, the reference fusion power and plasma power density can be

\*This work was supported by the General Atomics Internal R&D fund and TSI Research, under the Department of Energy, SBIR program.

determined. The reactor design physics and engineering parameters are given in Table I.

### TF-COIL CENTRAL COLUMN DESIGN

Twelve normal conducting single turn TF-coils are used for the design. As shown in Fig. 1, to minimize the electrical resistance by increasing the central column conductor cross-sectional area, the central column has a top and bottom to mid-plane taper-ratio ( $R_{Taper}$ ) of 2.5. The outer toroidal field coil is assumed to form the outer vessel surface and therefore the vacuum vessel wall. For the reference design, the inboard central column conductor has a radius of 0.8 m and a minimum outboard TF-coil return leg thickness of 0.13 m. The selected conducting material is GlidCop Al-25, cooled by water. GlidCop Al-25 is an  $Al_2O_3$  doped Cu alloy. As shown in [7], this dispersion-strengthened copper may be used up to temperatures in excess of  $500^\circ C$ . At room temperature it has yield strengths  $> 400$  MPa and thermal conductivity up to  $350$  W/m.K. Under irradiation its volumetric swelling is  $< 2\%$  up to an irradiated neutron fluence of  $150$  dpa at  $410$  to  $415^\circ C$ , with uniform elongation of less than a few % at

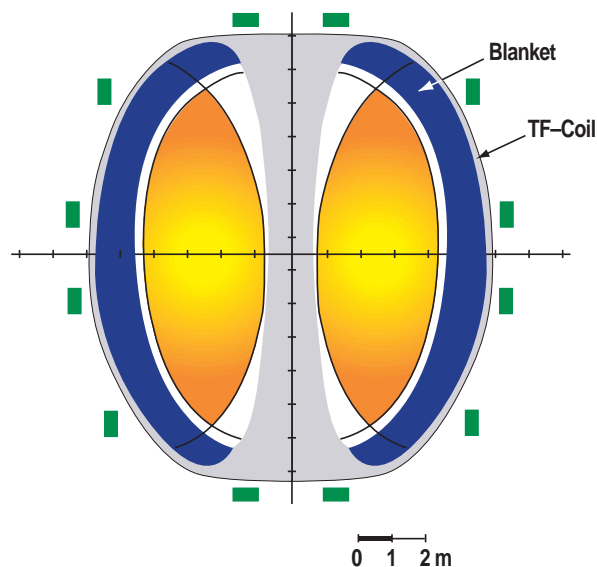

Fig. 1. LAR power plant core [1998 MW(e)].

Table I

Physics and Engineering Parameters of a LAR 1998 MWe Design

plasma aspect ratio, A	1.4
plasma vertical elongation	3.0
minor plasma radius, a, (m)	2.08
major toroidal radius, $R_o$ , (m)	2.9
plasma volume, ( $m^3$ )	740.7
first-wall surface area, ( $m^2$ )	493.3
radial profile exponent for density, $s_n$	0.25
radial profile exponent for temperature, $s_T$	0.25
toroidal beta, (%) volume averaged	62
poloidal beta, (%) volume averaged	1.43
on-axis toroidal field, (T)	2.17
plasma current, (MA)	31.5
plasma ion temperature, (keV) peak	25
plasma electron density, $n_e$ , ( $10^{20}/m^3$ )	2.38
plasma ion density, ( $10^{20}/m^3$ ) peak	1.74
Energy confinement time ( $\tau_{E,s}$ ) <sup>†</sup>	1.3
Kr concentration	0.0019
Helium concentration	0.1
effective plasma charge, ( $Z_{eff}$ )	3.59
average fusion power density, ( $MW/m^3$ )	6.6
fusion power, (MW)	4909
Toroidal field coil summary	
number of TF coils	12
mass of TF coil set, (tonne)	1193
TF-coil current per coil, (MA)	2.8
TF central column avg. current density, ( $MA/m^2$ )	18
TF coil resistive power consumption, (MWe)	270.9
Engineering summary	
thermal conversion efficiency, (%)	45
CD/heater [FWCD*] power, (MW)	58
Plant Q	4.2
total useful thermal power, (MW)	5833
gross electrical output power, (MWe)	2625
net electrical output power, (MWe)	1998
average 14.06-MeV neutron load, ( $MW/m^2$ )	7.96
LiPb blanket energy multiplication	1.4
Average first wall heat flux, ( $MW/m^2$ )	1.95
Divertor max. heat flux, ( $MW/m^2$ )	9.3

\*Fast wave Current Drive

<sup>†</sup> $\tau_E$  defined as plasma energy divided by heating power ( $P_\alpha + P_{fwd}$ )

temperatures below  $250^\circ C$  under a damage level of about 1 dpa. However, it has the typical irradiation damage concern of Cu-alloys which is the loss of ductility. Efforts are underway [8,9] to get around this low ductility property by design. For our calculation we focused on the resistance loss of the central column design, which is determined by:

$$R_{cc} = 2 \int_0^h \frac{dz}{\int_0^{R_o} \frac{2\pi r}{\eta(T, dpa, r, z)} dr} \quad (2)$$

where  $h$  is column half-height and the central column radius,  $R_o(r_o, z)$ , is given by:

$$R_o(r_o, z) = r_o \left[ 1 + \left( \frac{z}{h} \right)^2 (R_{Taper} - 1) \right] \quad (3)$$

where  $r_o$  is the mid-plane central column radius. The local Cu-alloy resistivity  $\eta$  (T, dpa) is determined by modeling the dpa distribution as,

$$\eta(T, dpa, r, z) = 1.9 \times 10^{-8} \left[ 1 + 0.00098(T - 20)^{1.2} \right] + 2.848 \times 10^{-10} dpa(r, z) \quad (4)$$

and the dpa ( $r, z$ ) is modeled by [10],

$$dpa(r, z) = 10 e^{-\left( \frac{r_o - r}{0.11} \right)} e^{-\left( \frac{z}{1.4} \right)^{1.6}} \quad (5)$$

The central column coolant volume fraction was assumed to be 15%. The average temperature of the central column was determined by iteration with the change in coolant outlet temperature. This design has a central column water

coolant velocity of 9.6 m/s, which is very close to the water and Cu-alloy erosion limit of 10 m/s.

### RADIATED CORE DESIGN

One of the critical components of the tokamak reactor is the divertor. It has to withstand high particle and surface heat fluxes. For the LAR design, the high plasma power density combined with a small divertor surface can produce a very severe local heat flux. A possible method to alleviate the difficulty is by the use of core and mantle radiation. With the assumption of ion, electron and impurities having the same temperature of 25 keV, the ion density can be written as,

$$n_i = \frac{\beta_T B_T^2}{2\mu_0 T_i} (1 + S_n + S_T) \left[ \frac{1 + f_z}{1 - f_z Z_z} + 1 \right]^{-1} \quad (6)$$

where,  $S_n$  and  $S_T$  are density and temperature shape factors,  $B_T$  is the magnetic field strength,  $f_z$  is the impurity concentration and  $Z_z$  is the atomic number of the impurity. As indicated, the increase of  $f_z$  corresponds to a decrease of  $n_i$ , therefore the reactivity of the fusion reaction given in (1) will be reduced. For the reference design, to reach a divertor maximum heat flux of 9.3 MW/m<sup>2</sup> and an average first wall surface loading of 1.95 MW/m<sup>2</sup>, the required  $f_z$  for Kr is 0.0019. When compared to the case of no added impurity, the maximum divertor and average first wall heat fluxes are 38 MW/m<sup>2</sup> and 1.46 MW/m<sup>2</sup>, respectively. The corresponding power output at higher ion density is 2314 MW<sub>e</sub>. This approach of core and mantle radiation has been demonstrated in TFTR [11], but is still at a very early stage of understanding. The concept of core radiation will need to be further verified by experiment.

### FIRST WALL AND BLANKET DESIGN

With the goal of designing to high surface heat flux and neutron wall loading, the combination of helium cooling, with the use of LiPb as the tritium breeder and V-alloy as the structural material is introduced. The configuration selected is the nested shell design as shown in Fig. 2, similar to the ARIES-I helium-cooled blanket design [12]. For the first wall, to design for the reference high surface heat flux of average/maximum of 1.95/2.69 MW/m<sup>2</sup>, the coolant has to have a maximum velocity of 154 m/s and is the dominant contributor to the first wall and blanket system pressure drop. For the blanket, to design for the average/maximum neutron wall loading of 7.96/11.2 MW/m<sup>2</sup>, and to meet the design temperature design criteria of V-alloy at  $T_{max} < 700^\circ\text{C}$  and LiPb  $T_{max} < 1000^\circ\text{C}$ , the nested shells behind the first wall will have to be spaced quite closely to each other. The smallest separation between the module wall and the first cooling shell is 7 mm. Volume fractions of this design are then

used for the neutronics evaluation. With a blanket thickness of 60 cm, and 90% enriched lithium, the 1-D tritium breeding ratio is 1.2. More detailed neutronics evaluation is in progress. Simple stress calculations for a single tube show that the 0.8 cm inside diameter and 0.2 cm wall thickness first wall tube can satisfy the primary and secondary stress limits of V-alloy at the location of maximum neutron and surface heat fluxes. Even though there are multiple barriers separating the liquid metal breeder and the central column water coolant, the selection of LiPb, which is much less chemically reactive than lithium, would be more acceptable under different accident scenarios. The materials lifetime is very uncertain. The fluence lifetime of 15 MW.y/m<sup>2</sup> for V-alloy is projected from limited irradiation results [13], similar lifetime for GlidCop is assumed for this evaluation. The potential material compatibility issue between the helium coolant (including oxygen and hydrogen impurities) with V-alloy could possibly be addressed by a suitable coating, but this will have to be demonstrated [14].

### SYSTEM RESULTS

A costing evaluation of the LAR reactor, was performed, similar to the ARIES approach [15]. Fig. 3 shows the COE as a function of major radius and thermal efficiency. As expected from the economy of scale, higher power output indicates lower COE. The increase in thermal efficiency corresponds to the increase of blanket coolant outlet temperature and the use of a closed cycle gas turbine (CCGT) power conversion system [14]. This improvement can be achieved by the application of a more advanced structural material like V-alloy/SiC metal matrix composite and SiC/SiC ceramic composite. These more advanced fusion structural material systems are in much earlier stage of development than V-alloys. Including the change out costs, replacement of the first 25 cm of the central column 14 times and the first wall and blanket modules 17 times, during the 30 years plant life at 75% availability, the reference design has a COE of 52.9 mill/kWhr. The costing results are list in Table II.

### WASTE DISPOSAL

The selected fusion power core materials of Helium, V-alloy, and LiPb, can be considered as low activation materials [17,18]. Cu can also be considered as low activation material if we use the waste disposal evaluation results from Fetter [19]. But the element Al which is present as the Al<sub>2</sub>O<sub>3</sub> dopant in GlidCop, due to the formation of the long half life transmuted isotope Al<sup>26</sup>, will not be qualified as class-C waste. Therefore Al<sub>2</sub>O<sub>3</sub> will have to be replaced by low activation dopant materials like SiO<sub>2</sub> or Y<sub>2</sub>O<sub>3</sub>. This is an item of material development that will have to be addressed.

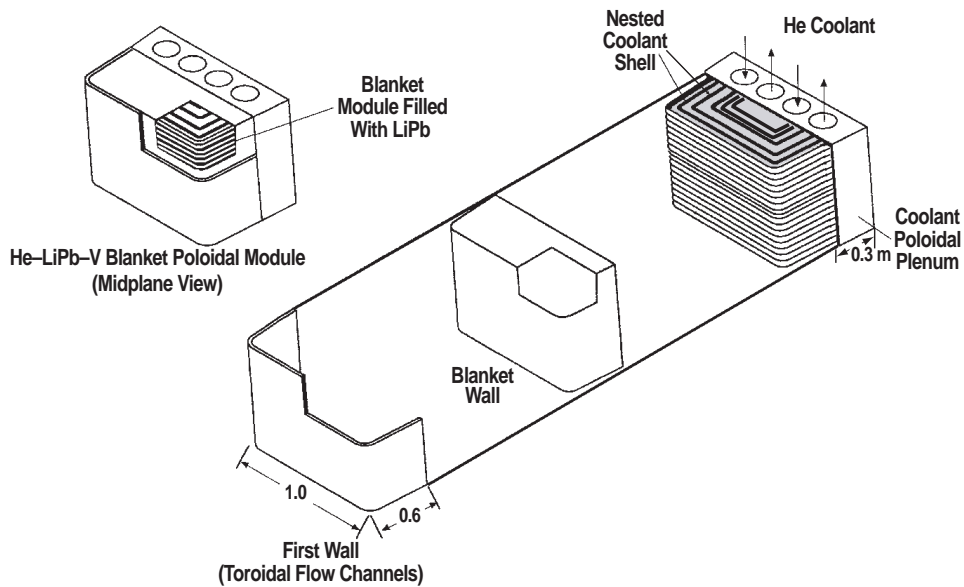

Fig. 2. High performance He-V-LiPb FW/blanket.

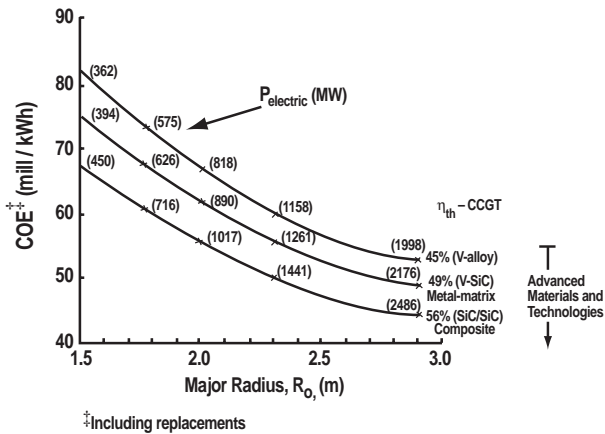

Fig. 3. LAR coe versus plant size and technology improvement.

### TECHNOLOGY RESEARCH AND DEVELOPMENT AREAS

This paper shows that the LAR reactor, based on aggressive design approach in physics and technology, can become a low activation economical fusion energy system. In addition to the experimental verification of physics performance, the following key technology research and development areas will need to be addressed:

- first wall and blanket design at high wall loading , with the goal of surface loading  $\leq 2 \text{ MW/m}^2$ , and average neutron wall loading  $\sim 8 \text{ MW/m}^2$ ,
- divertor and ash exhaust system design,
- unshielded TF-coil central column design including the effects of the cu-alloy material property change under neutron irradiation,
- core impurity radiation, with the goal of tailoring the transport power to the first wall and to the divertor,

- helium-cooled, V-alloy system design, with focus in addressing the issues of helium impurity compatibility with V-alloy and the reliability of the high gas pressure system,
- high pressure helium closed cycle gas turbine design development,
- low activation V and Cu-alloy and material recycling development,
- for higher thermal performance, advanced materials like V/SiC-fiber metal matrix, and SiC/SiC ceramic matrix should also be further developed,
- other key items not covered by this paper are maintenance approach, vacuum vessel and flexible TF-coil joints.

### CONCLUSIONS

Based on the aggressive design approach on physics and technology and subject to the limitations of scoping code analysis, the LAR concept has the potential to become an economically competitive fusion reactor. We find that impurity core radiation may be required for the distribution of heat fluxes to the first wall and divertor, and may also become a means for shut down control. Low activation design is possible with further Cu-alloy development. LAR concept shows clearly that economical fusion power may be limited by technology limitation and not by physics performance. High performance structural materials will improve the performance further. For timely development, it is crucial that LAR physics and technology be developed in parallel. Results of this study bring in focus the research and development needs of the LAR reactor concept and support further the motivation for following the LAR development path to attain the goal of fusion power.

Table II  
Costing of LAR reactor design

Account Number	Account Title	M\$ (1992)
20.	land & land rights	10.4
21.	structures & site facilities	557.5
22.	reactor plant equipment	1140.0
22.1.1	Fw/blanket/reflector	94.9
22.1.2	shield	36.0
22.1.3	magnets	85.3
22.1.4	supplemental-heating/CD systems	106.7
22.1.5	primary structure & support	119.1
22.1.6	reactor vacuum systems	90.0
22.1.7	power supply, switching & energy storage	134.3
22.1.8	impurity control	16.7
22.1.9	direct energy conversion system	0.0
22.1.10	ECRH breakdown system	4.3
22.1	reactor equipment	687.3
22.2	main heat transfer & transport systems	452.5
23.	turbine plant equipment	498.4
24.	electric plant equipment	159.5
25.	miscellaneous plant equipment	87.8
26.	special materials	60
90.	direct cost (not including contingency)	2753
91.	construction services & equip.	330
92.	home office eng. & services	137.7
93.	Field office eng. & services	165.2
94.	owner's cost	508.0
96.	project contingency	677.3
97.	interest during constr. (IDC)	755.3
99.	total cost (\$10 <sup>6</sup> )	5327
	unit overnight cost (\$/kWe)	4572
	capital return (mill/kWeh)	39.4
	plant availability	0.75
	decommissioning (mill/kWeh)	0.5
	fuel (mill/kWeh)	0.03
	LSA*=2 total COE <sup>†</sup> (mill/kWeh)	52.8 @ $\eta_{th}=45\%$
		49.3 @ $\eta_{th}=49\%$
		44.4 @ $\eta_{th}=56\%$

\*Level of safety assurance (16); account numbers from ARIES system code. <sup>†</sup>COE includes replacement costs

## REFERENCES

- [1] Y-K.M. Peng and D.J. Strickler, "Feature of spherical torus plasma," Nuclear Fusion 26, 769 (1986)
- [2] D.C. Robinson et al., "The way forward for the spherical tokamak," Proc. of the 12<sup>th</sup> topical meeting on the Technology of Fusion Energy, June 1996, Reno, Nevada.
- [3] C. Neumeyer et al., "Engineering overview of the National Spherical Torus Experiment (NSTX) This IEEE proceeding.
- [4] R.D. Stambaugh, V.S. Chan, R.L. Miller, and M.J. Schaffer, "The spherical tokamak path to fusion power,"

- 1997, to be published in Fusion Technology.
- [5] F. Najmabadi, et al., "Overview of ARIES-RS tokamak fusion power plant," ISFNT-4, Japan, to be published, also as UCSD report UCSD-ENG-040.
- [6] Bosch and Hale, Nuclear Fusion vol. 32, No. 4, 1992.
- [7] S.J. Zinkle and S.A. Fabritsiev, "Copper alloys for high heat flux structure applications," Fusion Materials, Semiannual Progress Report, DOE/ER-0313/16, march 31, 1994.
- [8] Y.K.M. Peng, "Physics and systems design for spherical torus based VNS," This conference.
- [9] R. Miller, UCSD, personal communication, ARIES-LAR work in progress by the ARIES team
- [10] E.T. Cheng et al., "Study of a spherical tokamak based volumetric neutron source," US-DOE Phase-I report, TSIR-45, April 1996.
- [11] S.C. Jardin, personal communication, presentation prepared by K. W. Hill et al., "Radiative mantle experiments on TFTR with Kr and Xe," ARIES project meeting, June 1997.
- [12] C.P.C. Wong, et al., "ARIES-I SiC composite low activation blanket design," ANS 9<sup>th</sup> Topical Meeting on the Technology of Fusion Energy, Oak Brook, Illinois, Oct. 1990.
- [13] M.C. Billone, "Design lifetime evaluation for V-4Cr-4Ti first-wall structural materials for fusion DEMO reactors," ANL, technical note prepared for the ARIES Engineering Team, personal communication.
- [14] C.P.C. Wong, et al., "Evaluation of U.S. DEMO helium-cooled blanket options," IEEE/NPSS Symposium on Fusion Engineering, Champaign, Illinois, September 1995.
- [15] C.G. Bathke et al., "A system analysis of the ARIES tokamak reactors," Fusion Technology, 1992, 2, 1658 (1992).
- [16] S.J. Piet, "Approaches to achieving inherently safe fusion power plants," Fusion Technology, 10 (1986); also "Inherent/passive safety for fusion," in Proc. 7<sup>th</sup> ANS Topical Meeting on Technology of Fusion Energy, Reno, NV (1986).
- [17] C.B.A. Forty and I. Cook, "Low activation structural material candidates for fusion power plants," UKAEA/Euratom Fusion Association, UKAEA FUS 365, June 1997.
- [18] S. Malang, et al., "Developmentn of self-cooled liquid metal breeder blankets," FKG, technical report FZKA 5581, November 1995.
- [19] S.A. Fetter, "Radiological hazard of fusion reactors: models and comparisons," Ph. D. Dissertation in Energy Resources, Universtiy of California, Berkeley, April 1985.