

Sustainable Design and Manufacturing: Including Environmental and Social Considerations

- or -

Avoiding short and long term harm

Bert Bras

Sustainable Design & Manufacturing

George W. Woodruff School of Mechanical Engineering

Georgia Institute of Technology

Atlanta, GA 30332-0405

www.sdm.gatech.edu

Engineering Code of Ethics

National Society of Professional Engineers Code of Ethics:

I. Fundamental Canons

Engineers, in the fulfillment of their professional duties, shall:

- *Hold paramount the safety, health, and welfare of the public.*
- ...

ASME Code of Ethics

The Fundamental Canons

- *Engineers shall hold paramount the safety, health and welfare of the public in the performance of their professional duties.*
- ...

Harm can be short term (immediate) but also long term!

Do you know about this?



**Insects Are Dying Off at a Scary Rate,
Putting Humanity at Risk (February 11, 2019)**

**THE
WALL STREET
JOURNAL**

Why a Decline in Insects Should Bug You

Research finds a sharp drop in flying insects over a few decades, but the causes are unclear

The New York Times

The Insect Apocalypse Is Here

What does it mean for the rest of life on Earth?

**The
Washington
Post**

**‘Hyperalarming’ study shows massive
insect loss**

What does this remind you off?

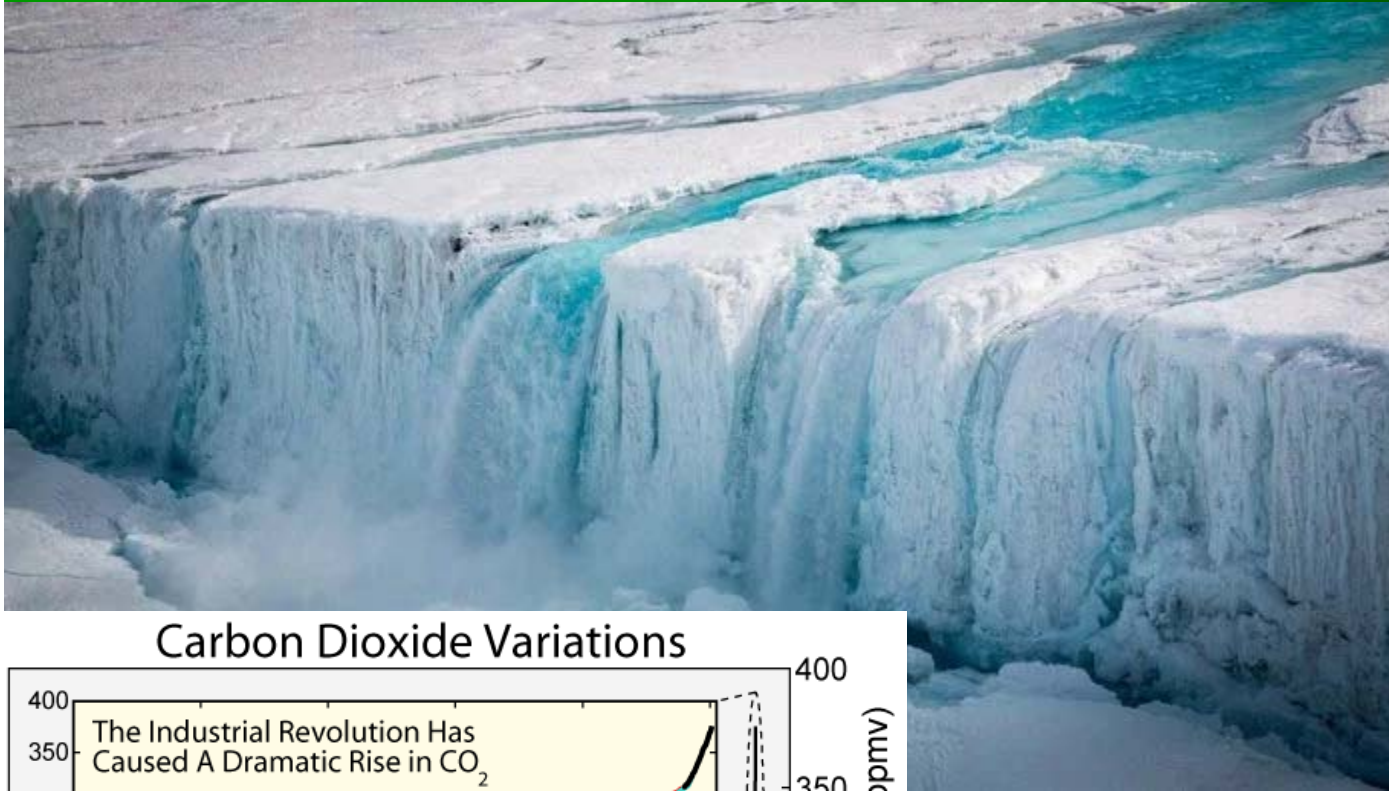

Carbon Dioxide Variations

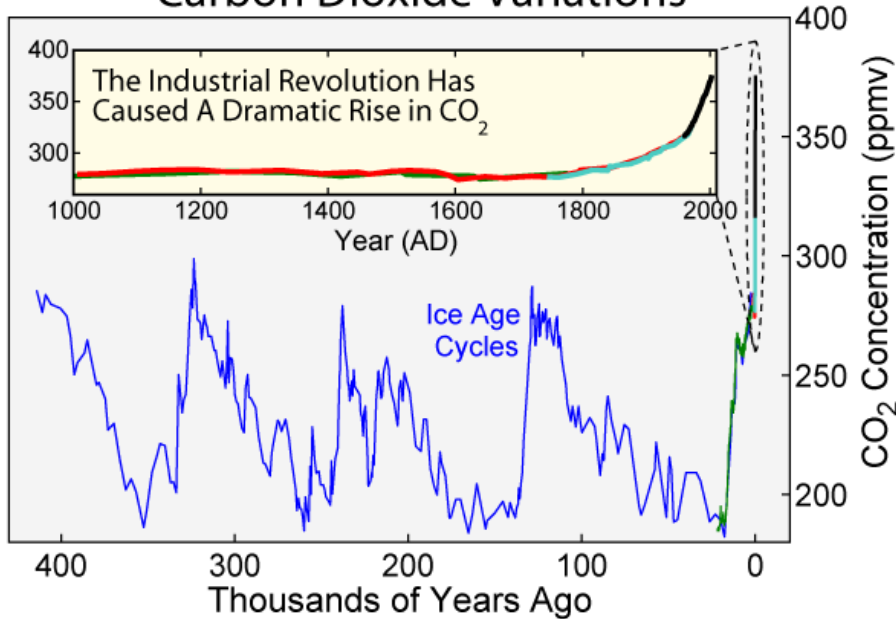

Climate Change is Serious Business



New coastline of The Netherlands if sea levels rose just 1 m (3 ft)

South Florida after 2 and 4 degree temp rise

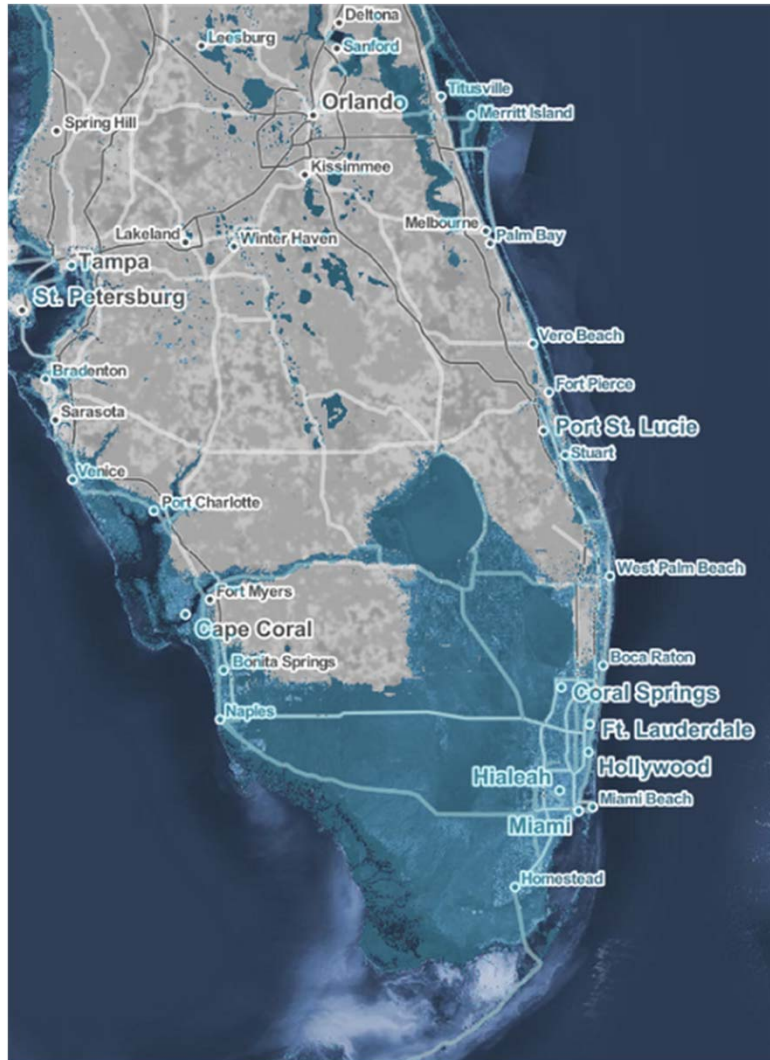

Some Preparations



- Rotterdam flood gates. Each gate is 72' high and 689' long Each ball joint weighs 680 tons
- Haringvliet flood gates. Note size of shutters compared to vans



Long Term View: Sustainable Development

“development that meets the needs of the present generation without compromising the needs of future generations.”

United Nations' World Commission on Environment and Development in their report “Our Common Future”, 1987

Sustainability: Working within the Physical Limits

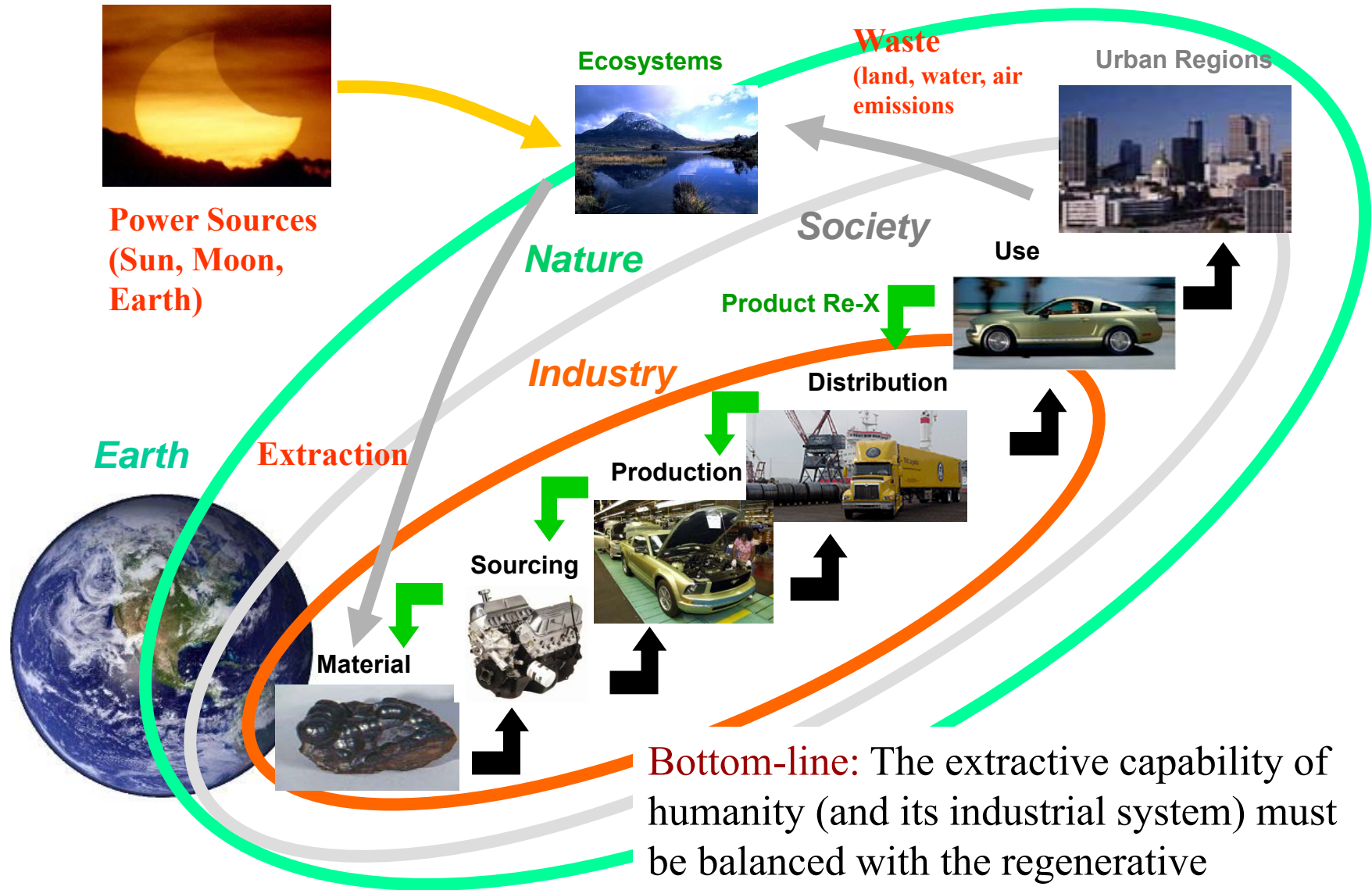

Bottom-line: The extractive capability of humanity (and its industrial system) must be balanced with the regenerative capacity of the Earth.

Sustainability's "Triple Bottom Line"

Sustainability is defined in three dimensions:

- **Environmental**

- Destroying our resources will hurt us long term
- Some materials already getting scarce

- **Financial**

- Being bankrupt helps nobody,
- Better (damage) accounting is needed

"People-Planet-Profit"

- **Social**

- Quality of Life should go up
- Workforce education and retention

"Green Economy"

"Green New Deal"

Goal is to have win-win-win technologies and solutions

Why do Businesses Care?

- **Legislation: It's the Law!**
 - It's the law. Clean Air Act, Clean Water Act, etc.
- **Risk & Liability: Your product can make somebody sick or kill**
 - Using hazardous materials or processes can be risky and create many liabilities
- **Customers: Nobody wants a product that kills or injures people, animals, etc.**
 - Awareness of environmental issues is increasing among customers – especially businesses
 - Industrial customers (e.g., Original Equipment Manufacturers) do not want (future) environmental liability for your product.
- **Image: Image is everything**
 - Being “green” is good.
- **ISO 14000: Your customer tells you to comply with Environmental Management Standard**
 - ISO 14000 (environmental management standards) certification has become an important element in doing business, like ISO 9000 (quality management standards).
- **It makes good business sense!**
 - Less waste = more money!
 - Driver for innovation and new creative solutions

A Real Story

Dutch officials seize cadmium-packed PlayStation kit

Sony wonders what fuss is about

By Tony Smith

Posted in Personal, 5th December 2001 11:51 GMT

Dutch customs officers yesterday impounded 1.3 million PlayStations and 800,000 accessory packs worth over 180 million Euro (\$160.25 million) after environmental protection inspectors discovered they were a potential threat to the environment.

Think-Pair-Share: Why is this bad? What is the problem? Who is to blame?

Image is Everything

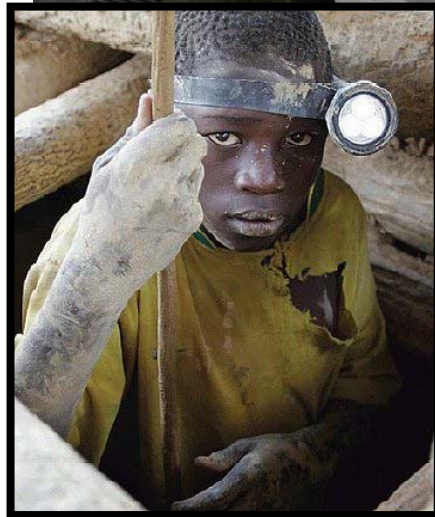

Important Concept: Life Cycle Thinking

- **Instead of “just” manufacturing, also think about environmental and social impacts during a products use, service and end of life**

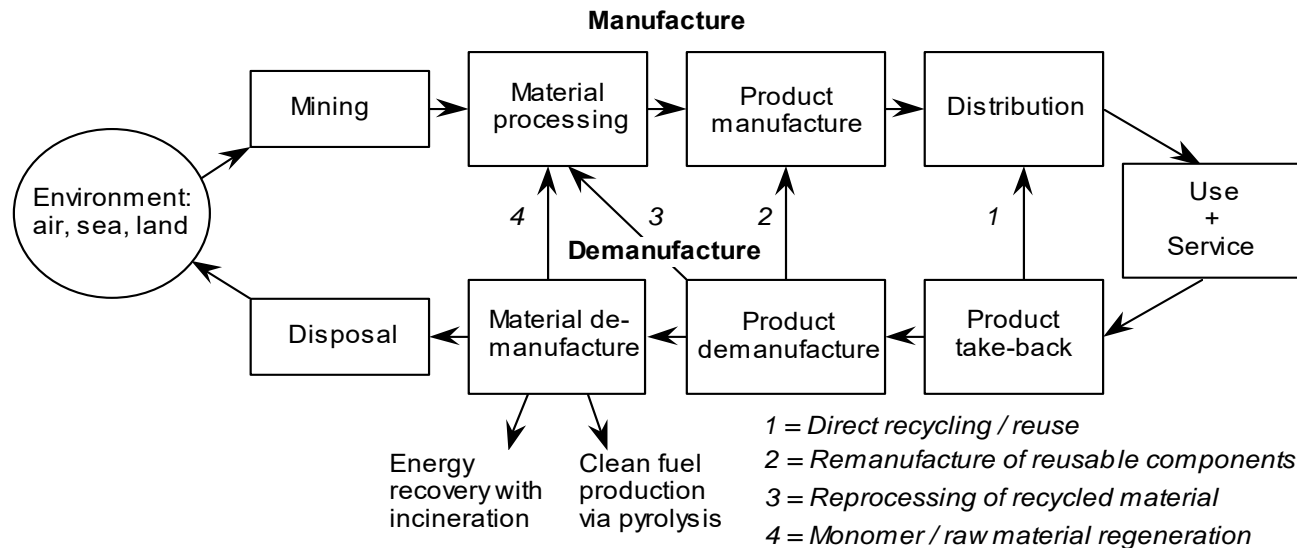

Schematic of Product Life-Cycle

Bras, B. (1997). "Incorporating Environmental Issues in Product Realization." *United Nations Industry and Environment* 20(1-2): 7-13.

- **A full assessment of impacts over a life cycle is called “Life-Cycle Assessment” (LCA) and is codified in ISO 14040 standards.**
 - LCA examines the environmental burdens and impact of a product over its entire life-cycle (see ISO 14040)

Upstream Sustainability Challenges Overseas

- China, India, etc., are all facing severe environmental, health, and quality of life problems as a result of their industrial growth
- As a US designer and firm, you may be contributing to their problems



Material Legislation is Everywhere

- Many materials are subject to legislations/regulations because they cause harm in some way
- Major US and EU companies all comply with legislation
- For an example list of international regulations, look at **automotive industry Global Automotive Declarable Substance List (GADSL)**:
 - 133 materials that may be in automotive parts
- You can download GADSL spreadsheet:
 - http://www.americanchemistry.com/s_plastics/doc.asp?CID=1106&DID=9293
 - **For automotive projects, check whether your design contains any of these materials**
 - **If so, disclose in report**

EPA and Toxic Release Inventory (TRI)

- **In the US, look at the EPA “list of lists” to see when you should worry about permits and special rules**
 - www.epa.gov/ceppo/pubs/title3.pdf
- You have to fill in a **TRI = Toxic Release Inventory** (like a tax report) if you use certain hazardous chemicals in manufacturing and filings are posted online:
 - www.epa.gov/triexplorer/
 - **Trivia:** According to TRI, who do you think is a) the biggest air polluter and b) the biggest land polluter?
- **Best thing is not to use any of these chemicals or let somebody else (your supplier) deal with it**

EU (& China): Restriction of Hazardous Substances (RoHS)

- **RoHS** is often referred to as the lead-free directive, but it restricts the use of the following six substances:

- Lead (Pb)
- Mercury (Hg)
- Cadmium (Cd)
- Hexavalent chromium (Cr6+)
- Polybrominated biphenyls (PBB)
- Polybrominated diphenyl ether (PBDE)

- PBB and PBDE are flame retardants used in several plastics.



- Lots of companies want suppliers to certify that they are “RoHS compliant”
- **If one part is not compliant, the whole product is not!**
- **Make sure your design is RoHS compliant!**
- **Check for RoHS compliance label when ordering**

Tool: Material Safety Data Sheets (MSDS)

- Check MSDS of materials if you want to be safe w.r.t. any health risks from a material you want to use in your design
 - Also think about worker safety (OSHA)
- MSDS can be obtained from material providers
 - Should be available upon request or online
- GREAT list of online MSDS and related databases is at:
 - <http://www.ilpi.com/msds/>
- Quick and easy online (free) MSDS database:
 - <http://hazard.com/msds/>
- **If applicable, include MSDS in your report (appendix)**

End Of Life

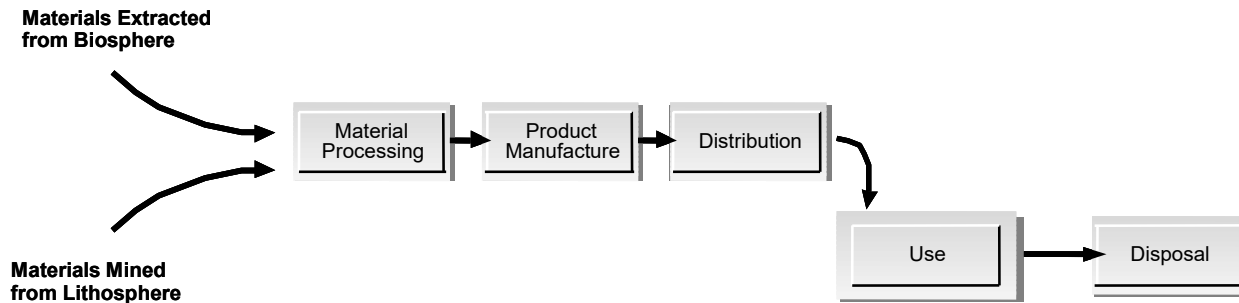

Linear Production: “Take, make, waste” (our current system)

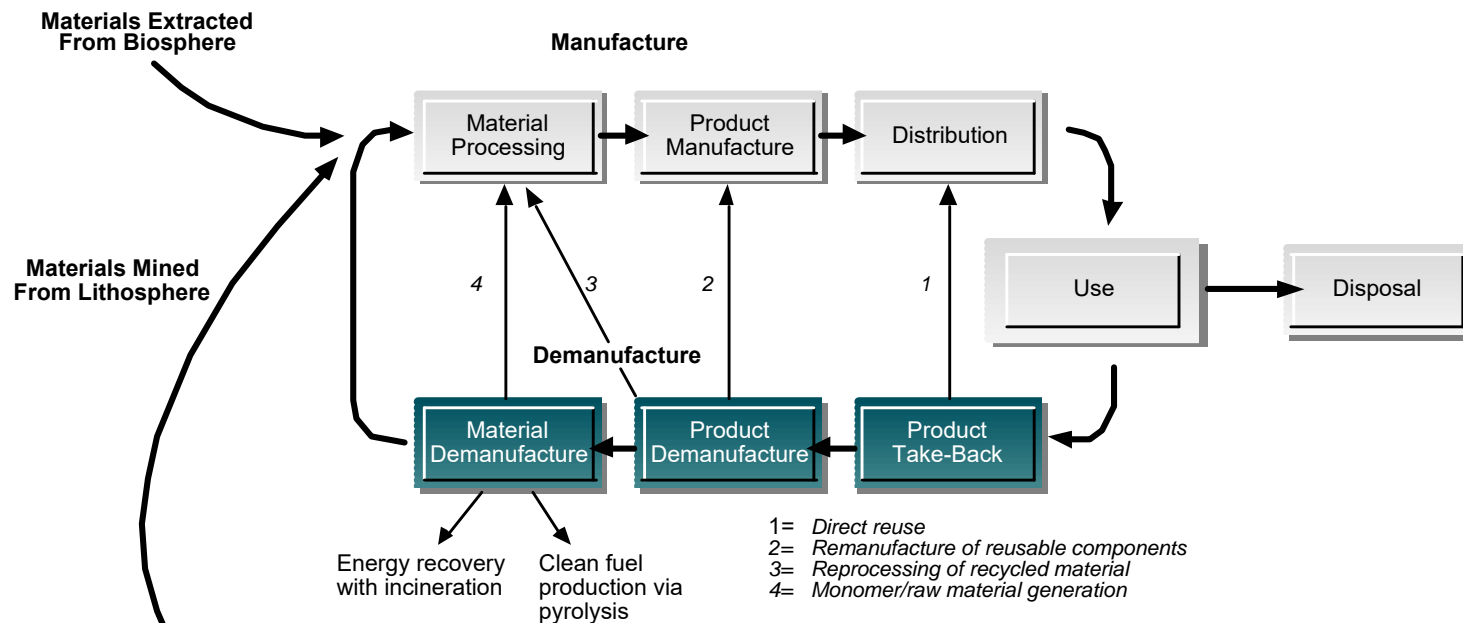

Closed Loop Production (“future” system)

WEEE Directive

- The **Waste Electrical and Electronic Equipment Directive** (WEEE Directive) is the European Community directive 2002/96/EC on waste electrical and electronic equipment (WEEE) which sets collection, recycling and recovery targets for all types of electrical goods.
- **Original Equipment Manufacturers are responsible for appropriate collection and treatment.**
- Each country can have different implementation
- **Think about how you will ensure that your (electronic) product will not end up on a landfill and can be recycled.**

Energy

- Energy is something we use a lot and comes from different sources with different consequences (including death)
- Much of our energy comes from materials
- Using energy has environmental consequences:
 - Air pollution
 - Green house gas emissions
 - Example: gasoline => 19.564 lbs CO₂/gallon
 - Water consumption
- DoE Energy Information Agency (EIA)
 - One of the best sources to find all kind of info on energy

Product Use Phase – Try to save energy!

- Typically, any energy consuming product has the largest environmental impact in its use phase
 - Exceptions always exist
- **Conservation is good!**
 - Every kWh or Joule saved by the product saves another 2-3 upstream
- **Beware of “rebound effect”**
 - You created a more efficient product, but now it is going to be used more

The Water Dimension



- Water is becoming more and more important
- Water is consumed everywhere in a product life cycle, incl. in energy production
 - Water Consumption: Freshwater withdrawals which are evaporated, incorporated in products and waste
 - Water Use (withdrawal): Water that goes into a system. Most of this typically leaves the system as waste water

Stage	Water Consumption (Liters)
Direct Material Production	5,569
Direct Parts Production	902
Direct Vehicle Assembly	670
Direct End of Life	259
Indirect: Material Production	11,859
Indirect: Parts & Assembly	5,757
Total	76,981

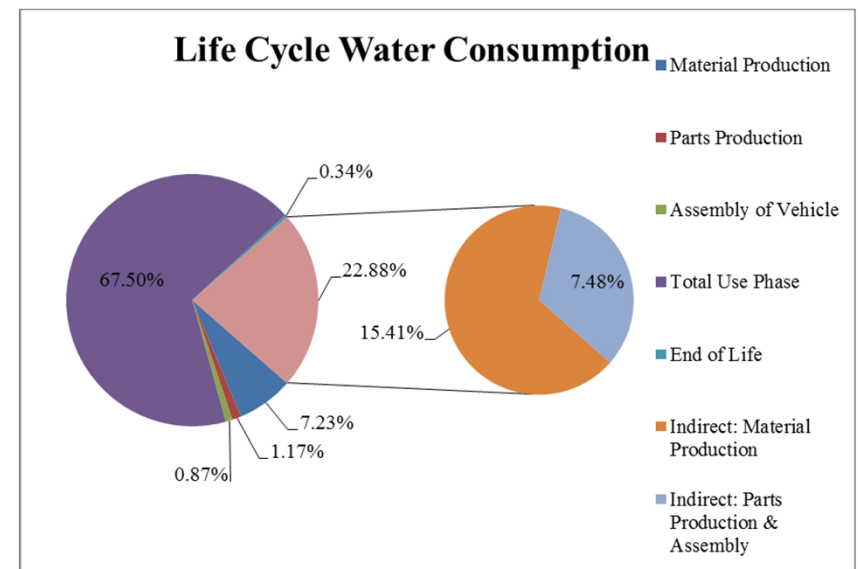

Tejada, F., Bras, B., and T. Guldberg (2012). Direct and Indirect Water Consumption in Vehicle Manufacturing. Paper DETC2012-71307, Proceedings of the ASME 2012 International Design Engineering Technical Conferences & Computers and Information in Engineering Conference, Chicago, IL, Aug 12-15.

Typical water consumption from electricity generation is around 0.5 gallons/kWh for thermo-electric plants

Example - Two Automotive Parts



Aluminum transfer case

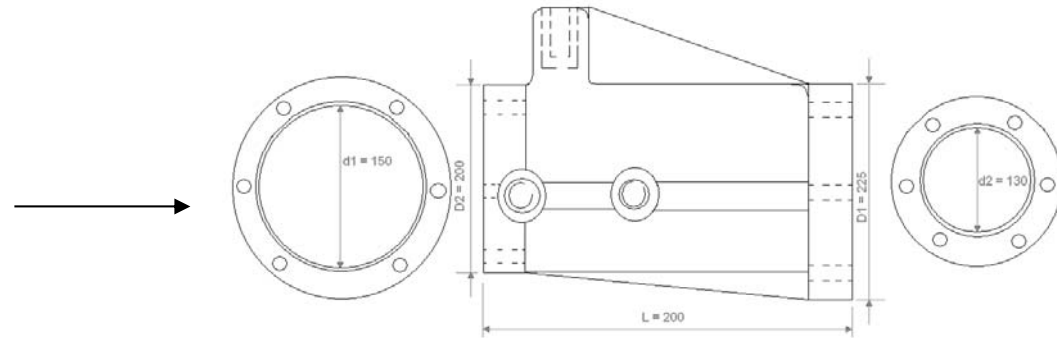

Steel pinion gear

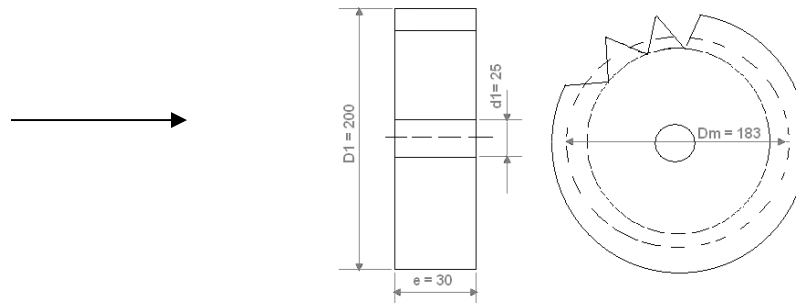

- Simple question: What is better?
 - Virgin manufacturing & disposal
 - Recycling
 - Remanufacturing

... and by how much?

Al Process Energy Consumption (kWh/ton)

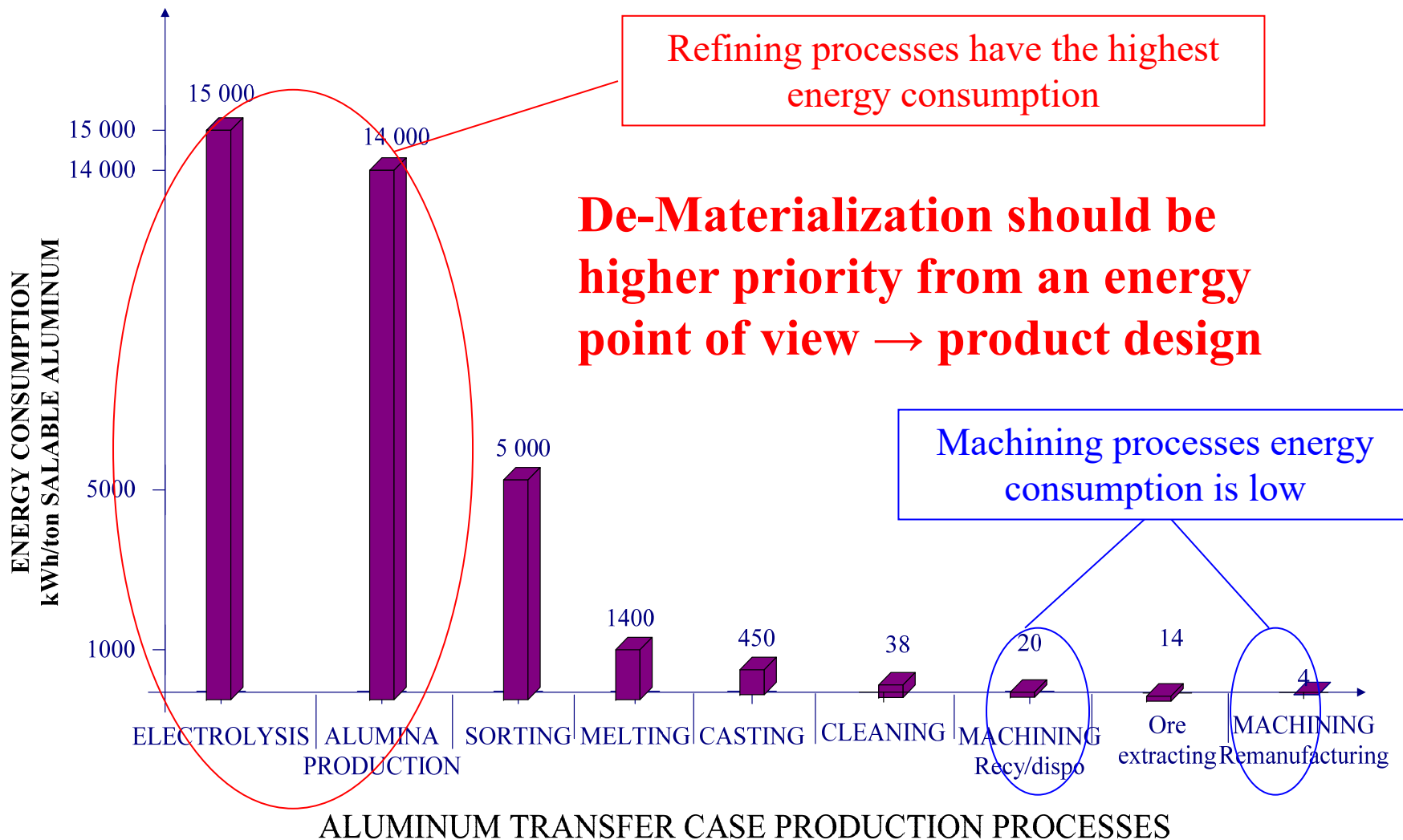

Steel Processing Energy Consumption

De-Materialization again will result in higher gains from an energy point of view

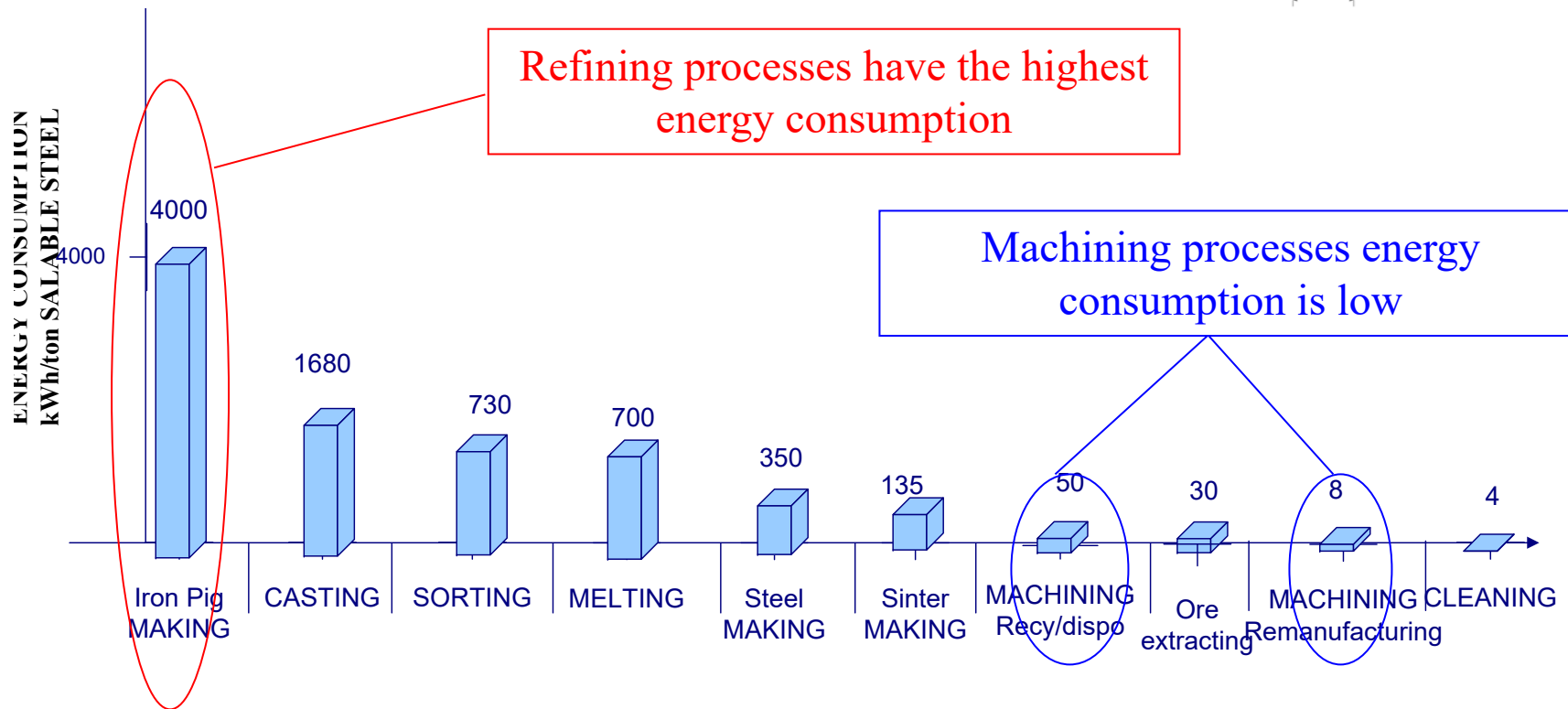
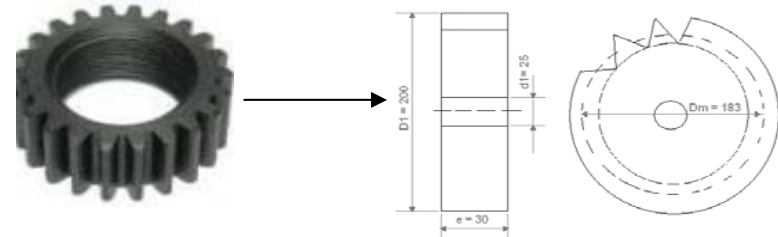

STEEL PRODUCTION PROCESSES

Energy Consumption in Manufacturing Sectors

Consumption of Energy (Site Energy) for All Purposes (First Use) for Selected Industries, 1998 and 2002 (Trillion Btu)

- **Manufacturing process energy savings are small when majority is embodied in upfront material production/refining**

2014 data is at:

<https://www.eia.gov/consumption/manufacturing/data/2014/>

NAICS	Subsector and Industry	MECS Survey Years	
		1998	2002
311	Food	1,044	1,123
312	Beverage and Tobacco Products	108	105
313	Textile Mills	256	207
314	Textile Product Mills	50	60
315	Apparel	48	30
316	Leather and Allied Products	8	7
321	Wood Products	509	377
322	Paper	2,747	2,363
323	Printing and Related Support	98	98
→ 324	Petroleum and Coal Products	7,320	6,799
→ 325	Chemicals	6,064	6,465
326	Plastics and Rubber Products	328	351
327	Nonmetallic Mineral Products	979	1,059
→ 331	Primary Metals	2,560	2,120
332	Fabricated Metal Products	445	388
333	Machinery	217	177
334	Computer and Electronic Products	205	201
335	Electrical Equip., Appliances, and Components	143	172
336	Transportation Equipment	492	429
337	Furniture and Related Products	88	64
339	Miscellaneous	89	71
	Manufacturing	23,796	22,666

Source: Energy Information Administration, Form EIA-846, Manufacturing Energy Consumption Surveys, 1998 and 2002, http://www.eia.doe.gov/emeu/efficiency/mecs_trend_9802/mecs9802_table1a.html

Regional Variation in Electricity CO₂ Emissions

Region	Carbon Dioxide (Metric tons/ MWh)
(1) New York, Connecticut, Rhode Island, Massachusetts, Vermont, New Hampshire and Maine	0.466
(2) New Jersey, Delaware, Pennsylvania, Maryland, West Virginia, Ohio, Indiana and Michigan	0.782
(3) Illinois and Wisconsin	0.638
(4) Missouri, Kentucky, Virginia, Arkansas, Tennessee, North Carolina, South Carolina, Louisiana, Mississippi, Alabama and Georgia	0.69
(5) Florida	0.678
(6) Texas	0.73
(7) Oklahoma and Kansas	0.867
(8) North Dakota, South Dakota, Nebraska, Minnesota and Iowa	0.875
(9) Colorado, Utah, Nevada, Wyoming and Montana	0.909
(10) New Mexico and Arizona	0.658
(11) Oregon, Washington and Idaho	0.147
(12) California	0.35
(13) Hawaii	0.858
(14) Alaska	0.749
(15) U.S. Territories	0.858
U.S. Average	0.676

Relocating manufacturing to a locality with renewable power often has a larger carbon footprint effect than any process efficiency improvement

- Formerly at: http://www.eia.doe.gov/oiaf/1605/emission_factors.html

GA Power Plant Bowen (Cartersville):

- CO₂ emission: 0.9 kg/kWh
- H₂O evaporation: 0.4 gallons/kWh

Opportunities

- **Think “holistically” about your product.**
- Your product is part of a bigger system
 - Thus, think “system” instead of “product”
- Thinking bigger may actually reduce cost
 - Can you reuse parts?
 - Can you lease instead of sell/buy?
 - Is the product really the end, or is it just a provider of a function?

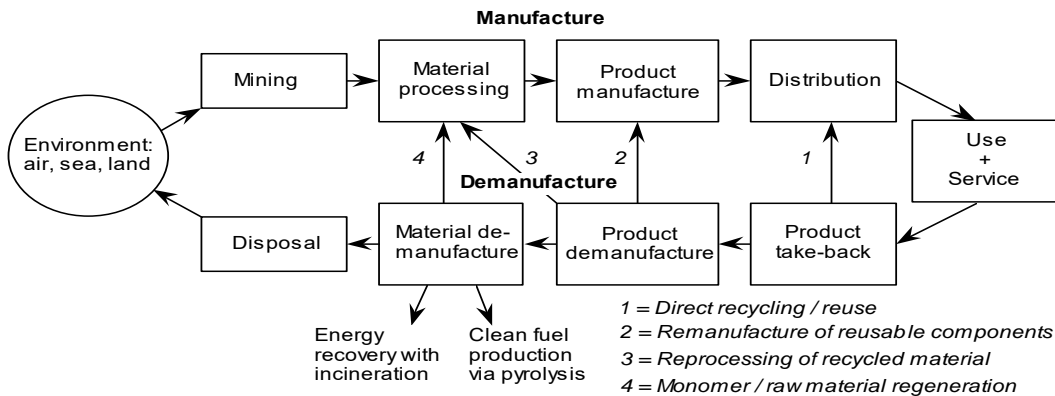

Importance of Sound Engineering

- Many systems are over-engineered
- **Appropriate technology and sound engineering can go a long way towards sustainability**
- Switching from Class 8 High Duty Diesel trucks to Ford F750 can provide significant savings.
- Ideas were triggered by quest for fuel savings.



TL Direct Lanes by Max. Wt.

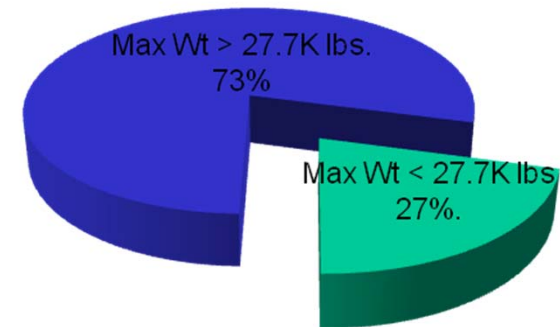

	Ford F-450/550	Class 6 Ford F-650	Class 7 Ford F-750	Class 8 (Freightliner Day Cab)
MSRP (New)	\$42,295/\$45,240	\$54,167	\$55,448	\$140,000
Price w/ Incentives	\$33,750/\$36,463	\$43,334	\$44,358	\$87,000
Curb Wt.	17,950 – 19,000 lbs. (GVWR)	9,300 lbs.	9,300 lbs.	16,000 lbs.
Gross Combined Wt. Rating	24,000 – 33,000 lbs.	50,000 lbs.	50,000 lbs.	80,000+
Towing Wt.	24,800 lbs.	40,700 lbs.	40,700 lbs.	57,000 lbs.
Max Payload	16,800 lbs.	27,700 lbs.	27,700 lbs.	44,000 lbs.
Output	325-362 hp	325 hp	325 hp	410-550 hp



In Closing

- In your project, you can
 1. Check and include MSDS sheets for potential problem materials
 2. Check for RoHS compliance when ordering (electronic) parts
 3. Quantify and minimize amount of materials used
 4. Quantify and minimize energy consumption
 5. Minimize wasteful manufacturing processes
 6. Increase recyclability by reducing number of different materials
 7. Avoid sourcing parts from questionable companies
 8. Etc.
- Think about and discuss the social and environmental consequences of your products
 - positive and negative
- **But don't forget the basics – good engineering & decision making is good for people-planet-profit!**