

Skill Profiles of College Students With a History of Developmental Language Disorder and Developmental Dyslexia

Journal of Learning Disabilities
1–13

© Hammill Institute on Disabilities 2020

Article reuse guidelines:

sagepub.com/journals-permissions

DOI: 10.1177/0022219420904348

journaloflearningdisabilities.sagepub.com



Stephanie N. Del Tufo, PhD¹*  and F. Sayako Earle, PhD²*

Abstract

Developmental language disorder (DLD) and developmental dyslexia (DD) are two prevalent subtypes of Specific Learning Disabilities (SLDs; *Diagnostic and Statistical Manual of Mental Disorders* [5th ed.; DSM-5]). Yet, little information is available regarding the distinct challenges faced by adults with DLD and/or DD in college. The purpose of the present report is to characterize the relative strengths and challenges of college students with a history of DLD and/or DD, as this information is critical for providing appropriate institutional support. We examined the cognitive skill profiles of 352 college students (ages 18–35 years), using standardized and research-validated measures of reading, spoken language, nonverbal cognition, and self-reported childhood diagnostic history. We classified college students as having DLD ($n = 50$), and/or DD ($n = 40$), or as typically developed adults ($n = 132$) according to procedures described for adults with DLD and DD. A structural equation model determined the cognitive, language, and reading measures predicted by the classification group. Adults with DLD demonstrated poor verbal working memory and speeded sentence-level reading. Adults with DD primarily demonstrated deficits in phonology-based skills. These results indicate that adults with DLD and/or DD continue to face similar challenges as they did during childhood, and thus may benefit from differentially targeted accommodations in college.

Keywords

specific learning disabilities, reading, disability, language, college, postsecondary

Academic accommodations that are provided to college students with specific learning disabilities (SLDs) are often not tailored to the skill profiles characteristic of SLD subtypes. Two examples of common SLD subtypes that are associated with a heightened risk of academic failure are developmental language disorder (DLD) and developmental dyslexia (DD; Conti-Ramsden et al., 2009). The skill profiles in school-age children with DLD and/or DD are well documented, facilitating distinct approaches for intervention for primary school students with DLD and DD (e.g., Cleave et al., 2015; Naha et al., 2019; Snowling, 2013). By comparison, the literature describing college-age adults with DLD and/or DD is sparse, particularly concerning skills that are important for academic achievement. Therefore, the current work aims to address this gap by examining the skill profiles of college students with DLD and/or DD.

The following review will briefly present the types of accommodations available to college students, followed by the known characteristics of adults with DLD and DD. Finally, this review will describe the various skills found to be predictive of academic success, which may be problematic for college students with DLD and/or DD. These

discussions will highlight the likelihood that college students with DLD and/or DD face distinct challenges that warrant tailored accommodations. As such, an empirical description of these challenges is a needed preliminary step toward provision of appropriate and individualized accommodations.

Accommodations for College Students With Disabilities

In the United States, the enrollment of students with SLDs in a 4-year degree program has gone from 2,243,000 in 2007–2008, to 2,563,000 in 2011–2012 (Snyder et al., 2016), amounting to roughly 60% of students with SLDs that now pursue a college education (Newman et al., 2011).

¹Vanderbilt University, Nashville, TN, USA

²University of Delaware, Newark, USA

*Both authors contributed equally to the present work

Corresponding Author:

F. Sayako Earle, PhD, Communication Sciences & Disorders, University of Delaware, 540 S. College Ave., Suite 220BB, Newark, DE 19713, USA.
Email: fsearle@udel.edu

However, only 34% of students with SLDs obtain a degree, as compared with 56% of students without SLDs (Newman et al., 2011). Thus, despite individuals with SLDs enrolling in college in greater numbers, there appears to remain substantial barriers to degree attainment (Conti-Ramsden et al., 2009).

Academic accommodations in college are designed to remove barriers to students' access to information and performance (Lewandowski et al., 2013). Such accommodations commonly consist of additional time on exams, access to technology during exams (e.g., calculator), taking exams in a separate classroom, access to the professor's notes, additional study guides, and/or tutoring (Mull et al., 2001; Weis et al., 2016). These accommodations, however, are not linked to a particular learning disability and have been found to benefit typical (nonimpaired) college students more than those with learning disabilities (Lewandowski et al., 2013). Moreover, individuals with certain SLD subtypes may be less likely to benefit from these broad accommodations over others (Weis et al., 2016). For example, Becker and McGregor (2016) found that decreased linguistic knowledge and poor verbal working memory (VWM) in adults with DLD was linked to difficulty in learning through listening to lectures. One might imagine that support for processing spoken language (e.g., ability to tape-record the lecture, access to key vocabulary to learn prior to a lecture) may benefit such individuals more than the general accommodation of having additional time on exams. In this way, having more information regarding the linguistic and cognitive skills associated with distinct SLD subtypes may lead to a more customized approach to accommodation (Weis et al., 2016).

College Students With Language-Based Disorders

DLD and DD have estimated prevalence rates of at least 7% (Tomblin et al., 1997), and 5% to 17% (D'Mello & Gabrieli, 2018) of the U.S. population, respectively. DLD is characterized by difficulty with spoken language (Leonard, 2014), and DD by a core deficit in decoding (*Diagnostic and Statistical Manual of Mental Disorders* [5th ed.; *DSM-5*; American Psychiatric Association (APA), 2013]; Lyon et al., 2003), in the absence of impaired hearing, neurological damage, or socioemotional disorders. Unlike DD, DLD may include those with nonverbal Intelligence Quotient (IQ) below normal limits (see Bishop et al., 2017); thus, DLD is a label that overlaps with, and is broader than, Specific Language Impairment. Approximately 43% to 55% of children identified with DLD meet criteria for DD, and vice versa (McArthur et al., 2000); however, it is unclear how often DLD and DD co-occur in adulthood. Moreover, the co-occurrence of multiple SLD subtypes, as well as the cumulative effect of multiple conditions, may

limit many adult students from admittance into postsecondary degree programs.

In childhood, DLD is associated with the omission of grammatical morphemes and difficulties in syntax (Leonard, 2014), a reduced vocabulary (Lee, 2011), and atypical speech processing (Ziegler et al., 2005). Low performance (e.g., a standard score of < 1.5 SDs below the mean, although criteria differ by state) on a standardized language battery, along with other clinical considerations, such as heightened familial risk, comorbidities, and informal observations of language function, support a diagnosis of DLD. Standardized instruments such as the *Test of Language Development—Fourth Edition* (TOLD-4, Newcomer & Hammill, 2008) assess discrete aspects of language (e.g., phonology, morphology, syntax, vocabulary), and then provide a composite score to reflect a child's overall abilities. As children with DLD demonstrate weaknesses in various areas of language, these composite scores are sensitive to a variety of language profiles that may be represented within the population of children with DLD.

Adults with a history of DLD continue to present with language-learning difficulties (e.g., Earle et al., 2018; McGregor et al., 2017); however, the language deficits apparent within the adolescents and adult age range differ from those evident in childhood. Specifically, adults with DLD do not present with obvious errors in grammatical and syntactic construction, but rather in higher-order language functions such as in narrative comprehension (e.g., of Miranda rights; Rost & McGregor, 2012) and in producing spoken and written narratives (Suddarth et al., 2012; Wetherell et al., 2007). While such difficulties are likely to impose challenges on academic achievement, it is unclear the extent to which DLD continues to be formally recognized as a diagnostic category in adults. Composite scores on instruments used to identify children with DLD are not designed to be sensitive to the higher-order language skills that are problematic for adults with DLD. Thus, adolescents with persisting DLD may obtain standardized scores that fall within normal limits, and at times result in disqualification from services and academic accommodations. Furthermore, most instruments lack normative scores by which to determine a diagnosis beyond adolescence.

Young adults with DLD who are dismissed from services may conclude that their linguistic skills no longer lag behind their peers. According to a national study focusing on the transition between secondary school and college, it was found that 52.4% of students with accommodations in high school considered themselves to no longer have a disability by the time they entered college (Wagner et al., 2005). In other words, many adults with DLD who would benefit from receiving accommodations in college may not be cognizant of their linguistic disadvantage (McGregor et al., 2016). This is problematic. In contrast with teacher identification of students who struggle during primary and

secondary school, institutions of higher learning require students to self-identify their needs and to obtain the required documentation to access services (Madaus & Shaw, 2006). Even within those who do self-identify as language-learning disordered, it is unclear how such individuals would access needed academic accommodations without a reliable means by which to receive a DLD diagnosis.

In contrast with DLD, the deficits observed in children and adults with DD do not appear to differ substantially. Both children and adults with DD have been observed with difficulty in phonological skills, word recognition, spelling, and decoding (Gabrieli, 2009; Goswami & Bryant, 2016; Snowling, 2013). While comprehension deficits are not a necessary characteristic of DD, reading comprehension may also be compromised by the lack of automaticity in decoding ability (Keenan et al., 2008). The relative stability of the core deficit across the life span allows for the same assessment tools to be used for the identification of both children and adults with DD. For example, performance in word-level reading depends heavily on competence in alphabetic coding (Goswami & Bryant, 2016), and is therefore sensitive to the problems in decoding presented by all individuals with DD regardless of age. Thus, while available standardized assessments of reading are by no means limited to word-level reading, some instruments are capable of identifying individuals with DD based on word-level reading in real words and nonwords (e.g., *Test of Word Reading Efficiency* [TOWRE], Torgesen et al., 1999). Moreover, this is a common method of identifying those with DD in research (e.g., Christodoulou et al., 2014; Gabrieli, 2009).

Skills and College Students With Language-Based Disabilities' Success

Although it seems clear that individuals with DLD and/or DD continue to present with language-based disabilities into adulthood, what is less known is how their skills inform the barriers that they face in college achievement. Below, we review various reading and other cognitive abilities that are predictive of academic success. Importantly, these are the skills that appear to be particularly compromised in children with DLD and/or DD, and therefore may continue to be problematic for these individuals in college.

Literacy Supporting Skills: Phonological Processing (PP) and Rapid Automatized Naming (RAN)

PP and RAN are skills that assist reading. These are critical areas to consider when examining skill profiles of individuals with DLD and/or DD (Ramus et al., 2013), as factors

that likely underlie performance on reading comprehension and fluency. PP encompasses phonological awareness and short-term memory. Phonological awareness refers to one's awareness of, and the ability to manipulate, the speech sound constituents of words (Lieberman et al., 1989). Phonological short-term memory is the ability to use phonological codes to represent information that is no longer present (Archibald & Gathercole, 2006). Performance on PP predicts reading ability throughout the lifespan (Svensson & Jacobson, 2006), and is impaired in both children and adults with DLD and DD (Fraser et al., 2009). Poor phonological short-term memory is considered a hallmark of DLD (Archibald & Gathercole, 2006), whereas poor phonological awareness is a hallmark of DD (Wagner et al., 1994).

RAN is the naming of a series of familiar items as quickly as possible (Denckla & Rudel, 1976). Like PP, RAN predicts growth in early reading development (Schatschneider et al., 2004). Performance deficits in RAN have been observed in both children with DLD and DD (Katz et al., 1993; Wolf, 1986). RAN deficits appear to persist in adults with DD (Vukovic et al., 2004); however, there is little information on RAN performance in adults with DLD.

Reading Skills: Comprehension and Fluency

Reading comprehension is a highly complex skill that refers to the ability to extract meaning from connected text, to draw inferences, and to surmise the macrostructure of a narrative. Reading fluency, that is, the ability to read quickly and accurately, is likewise a complex skill and is intertwined with comprehension (Kim et al., 2012). Reading comprehension is predictive of performance in college courses (Royer et al., 1987), and reading fluency has been tied to college readiness (Rasinski et al., 2017). Adults with DLD appear to have deficits in reading comprehension (Clegg et al., 2005); however, it is unclear whether they also experience difficulty with reading fluency. In contrast, adults with DD have deficits in both reading comprehension and fluency (Lefly & Pennington, 1991; Ransby & Swanson, 2003).

Intelligence Quotient (IQ)

General intelligence refers to mental ability underlying school performance (Spearman, 1904). The central components of general intelligence metrics are verbal and performance (nonverbal) IQ, both of which show relative stability across the lifespan ("crystallized" IQ). IQ is one of the best predictors of academic outcomes (Strenze, 2007). To qualify for an SLD diagnosis, one must demonstrate intelligence within normal limits (see *DSM-5*). Despite this, it has been observed that on average, individuals with DLD and/or DD perform less well than typical peers on tests of nonverbal

intelligence (Gallinat & Spaulding, 2014), and thus low nonverbal IQ is not considered an exclusionary criterion for DLD (Bishop et al., 2017). However, it is also possible that college students with language-based SLDs may have elevated nonverbal IQ relative to their peers. Perhaps those who achieve entry into college represent a subset of their population who have developed particularly good compensatory strategies (Nergård-Nilssen & Hulme, 2014).

Executive Function (EF)

EF refers to a set of top-down cognitive processes that are utilized when instinct or intuition would be inadequate, impossible, or misguided (Diamond, 2013). EFs are often regarded as more indicative of school readiness than IQ, entry-level reading or math skills (Blair & Razza, 2007; Morrison et al., 2010), and predicts school success (Best et al., 2011; Gathercole et al., 2004). Across various theoretical models of EF, three core processes are identified: inhibition (i.e., inhibitory control), cognitive flexibility (i.e., mental set shifting), and working memory (Diamond, 2013). Working memory involves manipulating information held in short-term memory (Baddeley & Hitch, 1994), and is closely related to short-term memory. Working memory is further specified by content: verbal and nonverbal (visual-spatial; Baddeley & Hitch, 1994). VWM is particularly relevant for both spoken and written language and reading function, as it is necessary for making sense of both spoken and written language (Smith & Jonides, 1999). Therefore, we included VWM as an independent construct and as a composite measure of global EF.

EF deficits in individuals with DLD are well documented (Kapa & Plante, 2015), particularly working memory (Archibald & Gathercole, 2006). Issues with EF are thought to underlie problems in language comprehension (Montgomery, 1995). Similarly, children with DD are reported to be impaired on several EF measures (Gioia et al., 2002), but working memory in particular appears related to reading (Daneman & Carpenter, 1980).

The Current Study

The purpose of the present report is to describe the reading and cognitive skills of college students with DLD or DD and to determine whether specific reading and/or cognitive skills have distinct associations with college students with DLD or DD. Our research question was whether or not college students with DLD and DD present with distinct weaknesses as compared with typical adults, and each other. Based on the previous literature, we hypothesized that college students with DLD will continue to present with problems in comprehension, phonological short-term and working memory, and other EF deficits. For college students with DD, we hypothesize that we will observe

continued problems with phonological awareness, reading comprehension and fluency, and EF. We furthermore predicted that we may observe elevated nonverbal IQ performance in the adults with DLD and/or DD that achieve college entry.

Method

Participants

To address our research aim, we conducted secondary analyses on an aggregated data set of standardized testing data collected across the two authors' dissertations at the University of Connecticut, under a single institutional review board (IRB) protocol. The University of Connecticut is a 4-year university with an acceptance rate of approximately 54%. Studies advertised for monolingual, native English speakers (18–35 years) with typical hearing, vision, neurological, and socio-emotional history. Across all studies, we aimed to recruit college students with varying reading and/or language abilities from very poor to good. Thus, advertisement materials often included verbiage that was specifically welcoming to individuals with a history of language and/or reading difficulties. Therefore, this data set likely includes a greater proportion of individuals from the low end of language and reading abilities spectra than is representative of the normative population. This data set includes test scores from a total of 365 students ($M_{\text{age}} = 19.84 [2.08]$, 118 males, 15 left-handed). Of these, self-reported racial/ethnic identities are as follows: 283 Caucasian, 14 African American, 12 Asian, 10 Hispanic, four Native American, 30 Multiracial, and two unknowns (declined to answer).

Classification of DLD and DD Status

As discussed in the literature review, there are practical challenges associated with identifying adults with DLD. To address the need for a classification procedure for adults with DLD, Fidler et al. (2011) devised a combination of measures and their respective weights for an equation that can classify adults with and without DLD. For the classification of college students with DLD, the authors specify two measures, the spelling test and the modified token test that, when combined, have a classification sensitivity of 80% and a specificity of 87%. In this procedure, one enters the raw scores of their version of a modified token test and a 15-word spelling test into the following equation derived from the authors' discriminant analysis: $y = (6.5727 + \text{spelling}) \times (-.2184 + \text{token}) \times (-.1298)$ (please see Fidler et al., 2011, for wordlist for the spelling test and additional details). Those with y values above 0 are identified as having DLD. Their method is quickly becoming the research standard for identifying adults with DLD (e.g., Earle et al.,

Table 1. Skill Profiles of College Students with DLD, RD, and TD.

Construct	Subtest/measure	DLD (<i>n</i> = 50)	RD (<i>n</i> = 40)	TD (<i>n</i> = 132)
Nonverbal cognition	Block design	54.59 (7.61)	56.33 (7.76)	55.70 (9.37)
	Matrix reasoning	54 (6.33)	53.7 (6.14)	52.01 (7.89)
Verbal working memory	Digit span forward	8.93 (2.21)	9.18 (2.69)	10.24 (2.88)
	Digit span backward	9.37 (2.38)	9.05 (2.23)	10.10 (2.85)
	Digit span sequencing	9.70 (2.55)	8.9 (2.71)	10.35 (2.89)
Rapid automatized naming	Letters	110.87 (6.28)	103.45 (15.92)	110.07 (12.88)
	Numbers	108.87 (6.28)	103.1 (6.17)	110.03 (5.56)
	Letter–number alternating	112.54 (8.04)	103.53 (8.61)	111.48 (13.77)
Phonological processing	Elision	10.15 (2.08)	9.82 (3.02)	9.94 (1.94)
	Blending	10.94 (2.34)	10.92 (3.29)	11.36 (1.93)
	Nonword repetition	9.09 (2.39)	7.74 (1.81)	9.78 (2.10)
Executive function	Global executive composite	47.68 (8.39)	50.71 (10.58)	48.48 (7.41)
Untimed word and nonword reading	Word identification	96.37 (22.51)	88.63 (9.26)	101.95 (10.88)
	Word attack	96.15 (18.12)	72.95 (14.01)	96.95 (16.88)
Reading comprehension	Passage comprehension	99.22 (25.00)	102.64 (11.86)	104.46 (13.58)
Reading fluency	Reading fluency	80.52 (13.56)	85 (14.46)	89.10 (11.27)
Timed word and nonword reading	Sight word efficiency	101.46 (13.30)	86.63 (11.83)	100.51 (13.38)
	Phonemic decoding	100.98 (17.17)	86.23 (8.49)	102.08 (12.68)
Fidler et al. (2011)	Modified token test	35.3 (4.38)	38.84 (4.44)	38.80 (5.48)
	Spelling test	6.9 (2.05)	9.52 (3.14)	11.23 (3.50)

Note. Means and standard deviations of performance scores from the test battery. Nonverbal cognition and executive function measures are expressed in *T*-scores. Rapid automatized naming, timed and untimed reading, and reading comprehension scores are standardized to a mean of 100 and a standard deviation of 15. Verbal working memory and phonological awareness/processing scores are standardized to a mean of 10 and a standard deviation of 3. As normative data are unavailable for the Fidler et al. (2011) measures, these are expressed in raw scores. DLD = developmental language disorder; RD = reading; TD = typical development of language and reading.

2018; McGregor et al., 2017), and was the method used for the current study.

We classified participants with DD as those individuals reading in the bottom 25th percentile, on real word and nonword reading across timed and untimed conditions. Specifically, those who obtained a standard score below 85 on at least two of the four Word Identification and Word Attack subtests of the *Woodcock Reading Mastery Tests–III* (WRMT-III; Woodcock, 2011) and the Sight Word Efficiency and Phonemic Decoding Efficiency subtests of the TOWRE (Torgesen et al., 1999) were classified as DD. We note that this classification reflects the term *dyslexia* as noted in the *DSM-5* (APA, 2013) to refer to a pattern of difficulties that reflect problems in word recognition and poor decoding abilities. This is distinct from the umbrella classification of specific reading disability, which has greater potential overlap with DLD, particularly in the area of reading comprehension that may arise from problems with spoken language comprehension.

All those identified with DLD and/or DD status self-reported a history of receiving some kind of language/reading services and/or accommodations. We did not restrict cohort membership based on what type of services they received, as the individuals themselves often did not remember. While not an exclusionary criterion, all participants in

the DLD or DD cohorts scored at or above 1.5 *SDs* below the mean on nonverbal IQ (means and standard deviations under Table 1).

These procedures resulted in a sample of 50 adults with DLD, and 40 adults with DD. Of these, seven adults met the criteria for both DLD and DD and remained part of the sample. Of the remaining 282 participants, 132 did not meet criteria for DLD or DD and were classified as having typical development of language and reading (TD). The remaining participants were unclassified due to missing data. Not all test materials were administered to all participants due to time constraints during the testing session.

Procedures

All participants provided informed consent prior to participation, in accordance with procedures approved by the University of Connecticut IRB. Upon enrollment, participants filled out an interview questionnaire asking for background demographic information such as handedness (Oldfield, 1971), language background, language and reading development, and development of motor skills. Participants completed 2 hours of standardized testing that included measures of nonverbal cognition, EF, timed and untimed word-level reading, reading comprehension,

reading fluency, spelling, spoken language processing, VWM, phonological awareness, PP, and rapid naming. All testing was conducted by one of the two authors. Raw score sheets were transformed to standard scores by the test administrator and then scored for a second time by a trained undergraduate student. Point-to-point reliability across measures, calculated for approximately 50% of the data set, was at 95%. All discrepancies in scoring were flagged and resolved by one of the two authors.

For PP, performance was measured on the elision, blending, and nonword repetition subtests of the *Comprehensive Test of Phonological Processing* (CTOPP; Wagner et al., 1999). Elision and blending subtests both require respondents to manipulate speech segments held in VWM. Nonword repetition is considered a measure of VWM, although it is clear that performance on this task relies to some extent on lexical knowledge (Munson et al., 2005). The former two (elision and blending) together comprise an index for phonological awareness, whereas the latter is considered an independent construct of PP (Wagner et al., 1999). This interpretation appears to be validated by our confirmatory factor analysis (CFA; see below). RAN was assessed using the letters, numbers, and the two-set subtests of the *RAN and Rapid Alternating Stimulus Test* (RAS; Wolf & Denckla, 2005). Reading comprehension was assessed using the Passage Comprehension subtest of the WRMT-III (Woodcock, 2011). Reading fluency scores were obtained from the Reading Fluency subtest of the *Woodcock-Johnson III Tests of Achievement* (WJ-III; Woodcock et al., 2001). To avoid confounds in IQ that include a verbal component, we measured nonverbal cognitive ability (NV-CA) using the Block Design and Matrix reasoning subtests that comprise the performance IQ of the *Wechsler Abbreviated Scale of Intelligence* (WASI; Wechsler, 1999). For EF, we asked participants to complete the *Global Executive Composite of the Behavior Rating Inventory of Executive Function-Adult* (BRIEF-A; Roth et al., 2005), which is a 75-item scale designed to assess EF and self-regulation; however, given our particular interest in VWM, we also obtained measures of VWM through the administration of the digit span forward, backward, and sequencing subtests of the *Wechsler Adult Intelligence Scale-Fourth Edition* (WAIS-IV; Wechsler, 2008).

Analyses

To evaluate model construct relationships simultaneously, we chose to address our research question using structural equation modeling (SEM) over multiple regression. All analyses were performed in *R* (R Development Core Team; Version 3.5.1, 2018) using the lavaan package (Rosseel, 2012). Specifically, we aimed to determine how the presence of DLD and/or DD affects various language,

reading, and cognitive skills. A Henze-Zirkler's test conducted on the set of (centered) variables indicated that this data set violates assumptions of multivariate normality. Therefore, we employed robust estimation in maximum likelihood for parameter estimation and the Satorra-Bentler scaled chi-square for model fit statistics. All available data from our data set were used (regardless of DLD/DD status) to model latent constructs. Missing values were calculated through case-wise maximum likelihood estimated imputation. We employed intercepts of 1 for latent variables.

We collapsed across our overlapping measures (e.g., three subtests of VWM) in our model by first specifying a set of four latent variables: NV-CA, VWM, RAN, and PP. NV-CA (Latent Variable 1) was estimated from observed scores on the Block Design and Matrix reasoning subtests of the *WASI* (Wechsler, 1999). VWM (Latent Variable 2) was estimated from digit span forward, backward, and sequencing subtests of the *WAIS-IV* (Wechsler, 2008). RAN (Latent Variable 3) was estimated from the subtests of the RAN/RAS (Wolf & Denckla, 2005). PP (Latent Variable 4) was estimated from scores on the elision, blending, and nonword repetition subtests of the CTOPP (Wagner et al., 1999).

We validated this measurement model through an initial CFA that included the measures and hypothesized latent variables, with each latent construct predicting its indicator variables. Unstandardized estimates for block design, RAN numbers, digit span forward, and elision subtests were set to 1 within their respective latent constructs. To meet the unidimensionality requirement for the model, an item-deletion procedure was followed for low factor loading items. This prompted us to remove nonword repetition as an indicator of PP, significantly improving the CFA model fit ($\Delta\chi^2 = 33.55$, $\Delta df = 9$, $p < .001$). We, therefore, include nonword repetition as a separate variable in our SEM. The resultant model met criteria for convergent, construct, and discriminant validity: All items were statistically significant at an alpha of .05. The final model had excellent fit according to absolute, incremental, and parsimonious fit indexes ($\chi^2 = 36.836$, $df = 29$, $p = .150$; comparative fit index [CFI] = .98, the Tucker-Lewis index [TLI] = .97, and the root mean square error of approximation [RMSEA] = .030, 90% confidence interval [CI] = [0.000, 0.056], $\chi^2/df = 1.27$). Finally, modification indexes on all items were low (<15) as were the residual correlations, which together indicated that there was low redundancy between measures in the model. All of the standardized assessments themselves report high internal consistency between their subtests. Notably, our constructs included a small subset of the indicators; thus, we expected lower internal consistency (Cronbach's α for NV = .47, DS = .62, RAN = .59, PA = .41). Please see the appendix for the residual correlations and path diagram of our CFA.

The SEM, therefore, included the four latent variables, nonword repetition, and the remaining variables: reading fluency, passage comprehension, and the global executive composite (GEC; as our index of EF) that were entered directly. Outcome measures (NV-CA, VWM, RAN, PP, nonword repetition, reading fluency, passage comprehension, and the GEC) were regressed with language (DLD) and reading (RD) status as separate binary factors, with DLD and DD each coded as 1. As our purpose in performing the SEM was to conduct regression analyses on all of our constructs, we did not use a model selection procedure.

Results

The final SEM model fit was excellent ($\chi^2 = 78.66$, $df = 65$, $p = .119$; CFI = .95, TLI = .91, and RMSEA = .040, 90% CI = [0.000,0.069]). Factor loadings for all latent variables were statistically significant. DLD status significantly predicted VWM ($\beta = -1.12$, $SE = 0.40$, $Z = -2.82$, $p = .005$), nonword repetition ($\beta = -0.99$, $SE = 0.44$, $Z = -2.56$, $p = .024$), and reading fluency ($\beta = -7.51$, $SE = 2.48$, $Z = -3.03$, $p = .002$). In contrast, DD status significantly predicted PP ($\beta = -1.21$, $SE = 0.50$, $Z = -2.40$, $p = .016$), nonword repetition ($\beta = -2.41$, $SE = 0.49$, $Z = -4.90$, $p < .001$), and RAN ($\beta = -4.02$, $SE = 1.26$, $Z = -3.20$, $p = .001$). In summary, positive DLD or DD status in college was associated with distinct skill profiles, with an overlapping deficit in nonword repetition ability (see Figure 1 for a graphical depiction of the various relationships, along with the standardized coefficients).

Discussion

The purpose of the present report is to provide information regarding the reading and cognitive skills of college students with DLD and/or DD (see Figure 1 and Table 1 for summaries). To address this objective, regression analyses were conducted on various language, reading, and nonverbal abilities through SEM. We found DLD status in college to be negatively associated with VWM, nonword repetition, and reading fluency. DD status was associated with phonology-based problems, namely, PP, nonword repetition, and RAN.

The findings that VWM and nonword repetition are associated with DLD status are consistent with the literature on children with DLD (Archibald & Gathercole, 2006). Inconsistent with our hypothesis, it was reading fluency, rather than comprehension, that was associated with DLD status in college students. Importantly, this measure of reading fluency assessed participants' ability to read a series of statements quickly, and make a semantic judgment regarding each statement. In other words, scores on this task reflect both speed *and* basic comprehension, unlike measures of oral reading fluency that assess reading speed alone. Taken

together, this may suggest that college students with DLD do not struggle with reading comprehension in general, but demonstrate deficits under timed conditions. Together with the poor VWM, which has been linked to difficulty in processing spoken language during lectures (Becker & McGregor, 2016), there may be two critical accommodations for college students with DLD: audio or video-recorded lectures, and untimed testing.

The finding that DD status is associated with phonology-based deficits is consistent with a vast literature linking phonological abilities to spelling and decoding ability throughout the life span (Goswami & Bryant, 2016). This may suggest that writing down unfamiliar words based on how they sound, which is particularly relevant for note-taking, may be a challenge for college students with DD. Thus, the provision of note-takers during lectures may also serve as an important accommodation for college students with DD. Interestingly, we also observed a statistical trend ($p = .057$) toward a positive association with NV-CA, indicating that college students with DD may have elevated NV-CA. This may suggest that college students with DD represent a subset of their population that is particularly good at compensating for their deficits.

As discussed above, nonword repetition appears to rely both on PP ability and on lexical knowledge. As such, nonword repetition is a "catch-all" task, and thus, it is not surprising that both DLD and DD status were both associated with deficits in this task. Surprisingly, neither DLD nor DD status was associated with deficits in EF, and moreover, DD status was not associated with reading comprehension or fluency. Given that these are documented areas of difficulty for these populations (Kapa & Plante, 2015; Shafir & Siegel, 1994), we may be capturing characteristics specific to the individuals who achieve college entry, who may have stronger skill profiles relative to others in their respective populations.

To summarize, these findings reflect patterns that resonate with previous findings on childhood populations with DLD and DD, and yet their profiles are slightly different in college. These findings indicate that these adults clearly continue to present with challenges in adulthood that are likely to present substantial barriers to educational attainment. Moreover, the distinct skill profiles associated with DLD and DD suggest that SLD subtypes may warrant accommodations that are tailored to the strengths and weaknesses associated with each disability subtype. Furthermore, college students with DLD and/or DD may represent particular subsets of their respective populations with higher EF and NV cognitive capacities than the wider DLD and DD populations. This may suggest that, given appropriate accommodations, they will be able to succeed in college and ultimately earn their degrees. This finding may also have implications for the broader applicability of research studies conducted on college students with DLD and/or DD.

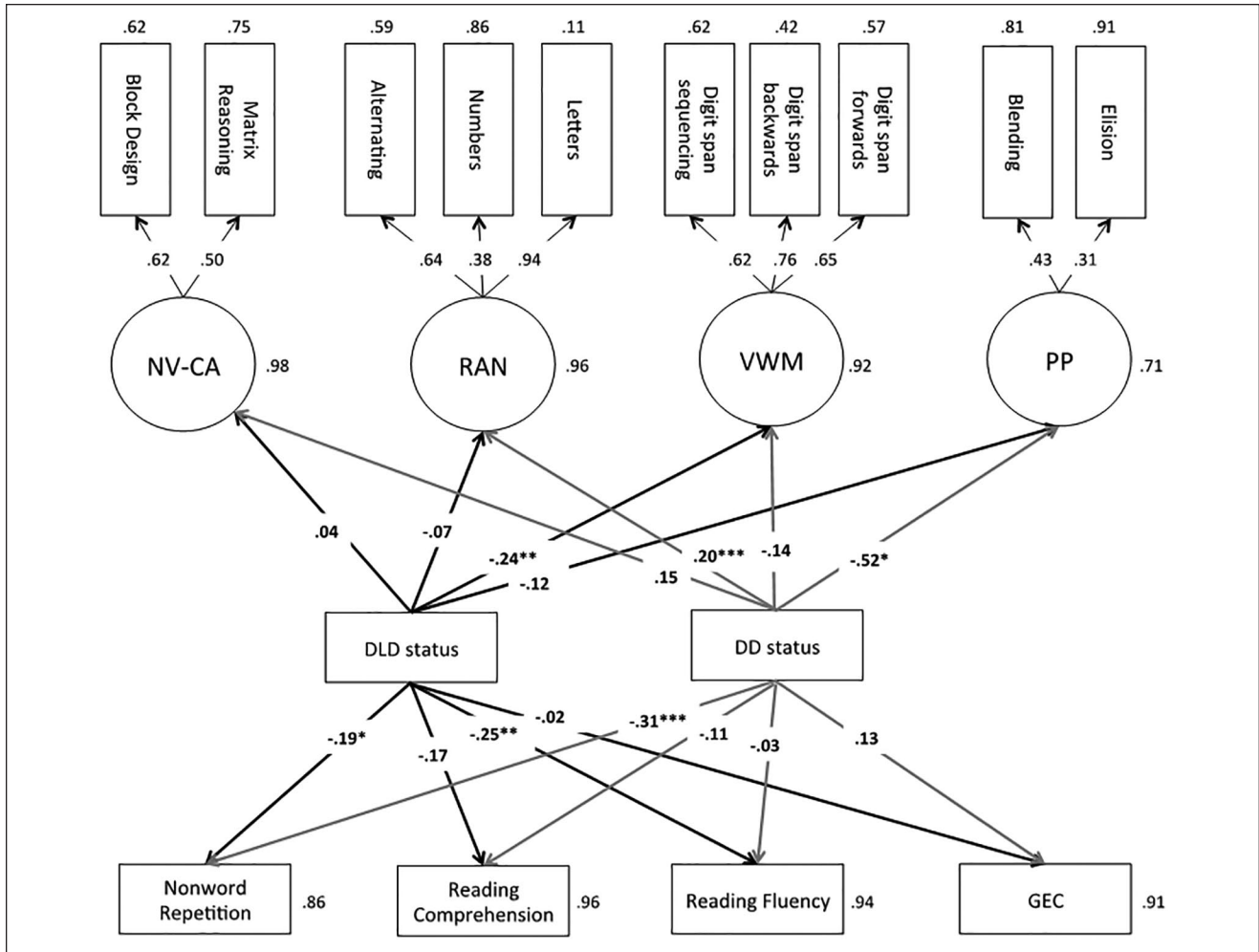

Figure 1. Diagram for the structural equation model with standardized coefficients.

Note. Covariances between latent and manifest variables were modeled, but not included in the above diagram for ease of viewing. Model fit indexes: $\chi^2 = 36.836$, $df = 29$, $p = .150$; comparative fit index (CFI) = .98, the Tucker–Lewis index (TLI) = .97, and the root mean square error of approximation (RMSEA) = .030, 90% confidence interval (CI) = [0.000, 0.056]. NV-CA = nonverbal cognitive ability; RAN = rapid automatized naming; VWM = verbal working memory; PP = phonological processing; DLD = developmental language disorder; DD = developmental dyslexia; GEC = global executive composite.

*Significant at .05 level. **Significant at .01 level. ***Significant at .001 level.

There are several limitations to the current study. First, only seven adults met criteria for both DLD and DD, and thus we have insufficient data to examine this subset more closely. In addition, we utilized our only measures of spoken language processing and word-level reading abilities for classification purposes, we were not able to additionally examine these constructs within our model. Participants

were not asked to describe whether and how their decreased language and reading abilities continued to affect their academic lives. Similarly, participants were not asked to describe their experiences accessing services and accommodations within a postsecondary educational environment. These are potentially important future directions to pursue.

Appendix

Table A1. Correlation Matrix for Assessments Administered.

Performance Measure	NV-CA		VWM			RAN			PP			Pass comp	
	BD	MR	DSF	DSB	DSS	Num	Let	Alt	Eli	Ble	NWR		GEC
MR	.3*												
DSF	.08	.02											
DSB	.2*	.19	.43*										
DSS	.18	.14	.24*	.33*									
Num	-.04	.03	.03	.08	.06								
Let	.03	-.07	.2*	.19*	.22*	.47*							
Alt	-.03	-.03	.11	.11	.07	.28*	.49*						
Eli	.10	.13	.05	.11	.10	.06	-.01	-.02					
Ble	.12	.13	.16	.15	.06	.06	.04	.00	.26*				
NWR	.04	-.07	.15	.04	.01	.07	.15	.05	.10	.12			
GEC	-.04	.04	-.02	.08	.09	-.11	-.03	.00	-.08	-.06	7.00		
Pass comp	.25*	.31*	.09	.07	.06	.01	.06	.06	.15	.27*	.09	-.12	
Reading fluency	-.08	-.13	-.02	-.01	-.08	.10	.12	-.02	.03	.06	.07	-.08	.00

Note. NV-CA = nonverbal cognitive ability; BD = block design; MR = matrix reasoning; block design and matrix reasoning are subtests of the WASI (Wechsler, 1999). VWM = verbal working memory; DSF = digit span forward, DSB = digit span backward, DSS = digit span sequencing; they are subtests of the WAIS-IV (Wechsler, 2014). RAN = rapid automatized naming; Num (numbers), Let (letters), and Alt (alternating) are subtests of the RAN/RAS (Wolf & Denckla, 2005). PP = phonological processing; Eli (elision), Ble (blending), and NWR (nonword repetition) are subtests of the CTOPP (R. K. Wagner et al., 1999). The Global Executive Composite (GEC) is a composite score obtained from the BRIEF (Roth et al., 2005). Pass Comp = passage comprehension, a subtest of the WRMT-III (Woodcock, 2011); Reading fluency is a subtest of the WJ-III (Woodcock et al., 2001). WASI = Wechsler Abbreviated Scale of Intelligence; WAIS-IV = Wechsler Adult Intelligence Scale—Fourth Edition; RAS = rapid alternating stimulus; CTOPP = Comprehensive Test of Phonological Processing; BRIEF = Behavior Rating Inventory of Executive Function; WRMT-III = Woodcock Reading Mastery Tests—III; WJ-III = Woodcock–Johnson III Tests of Achievement.

*Statically significant at .05 level after controlling for family-wise error rate.

Table A2. Residual Correlations for Confirmatory Factor Analysis.

Performance Measure	BD	MR	DSF	DSB	DSS	Let	Alt	Num	Elis	Blend
BD	.00									
MR	.00	.00								
DSF	-.06	-.12	.00							
DSB	.04	.02	.02	.00						
DSS	.09	.03	-.03	-.01	.00					
Let	.04	-.03	.04	-.05	.05	.00				
Alt	-.07	-.02	.03	-.03	-.03	.00	.00			
Num	-.06	.05	-.05	-.05	-.02	.00	.05	.00		
Elis	.00	.02	-.04	.00	.02	.02	.00	.08	.00	
Blend	-.01	-.01	.05	.00	-.05	-.01	.02	.08	.00	.00

Note. Model fit indexes: $\chi^2 = 36.836$, $df = 29$, $p = .150$; comparative fit index (CFI) = .98, the Tucker–Lewis index (TLI) = .97, and the root mean square error of approximation (RMSEA) = .030, 90% confidence interval (CI) = [0.000, 0.056]. NV-CA = nonverbal cognitive ability; block design (BD) and matrix reasoning (MR) of the WASI (Wechsler, 1999). VWM = verbal working memory; digit span forward (DSF), backward (DSB), and sequencing (DSS) of the WAIS-IV (Wechsler, 2008). RAN = rapid automatized naming; numbers (Num), letters (Let), and the alternating (Alt) of the RAN/RAS (Wolf & Denckla, 2005). PP = phonological processing; elision (Elis) and blending (Blend) are subtests of the CTOPP (R. K. Wagner et al., 1999). WASI = Wechsler Abbreviated Scale of Intelligence; WAIS-IV = Wechsler Adult Intelligence Scale—Fourth Edition; RAS = rapid alternating stimulus; CTOPP = Comprehensive Test of Phonological Processing.

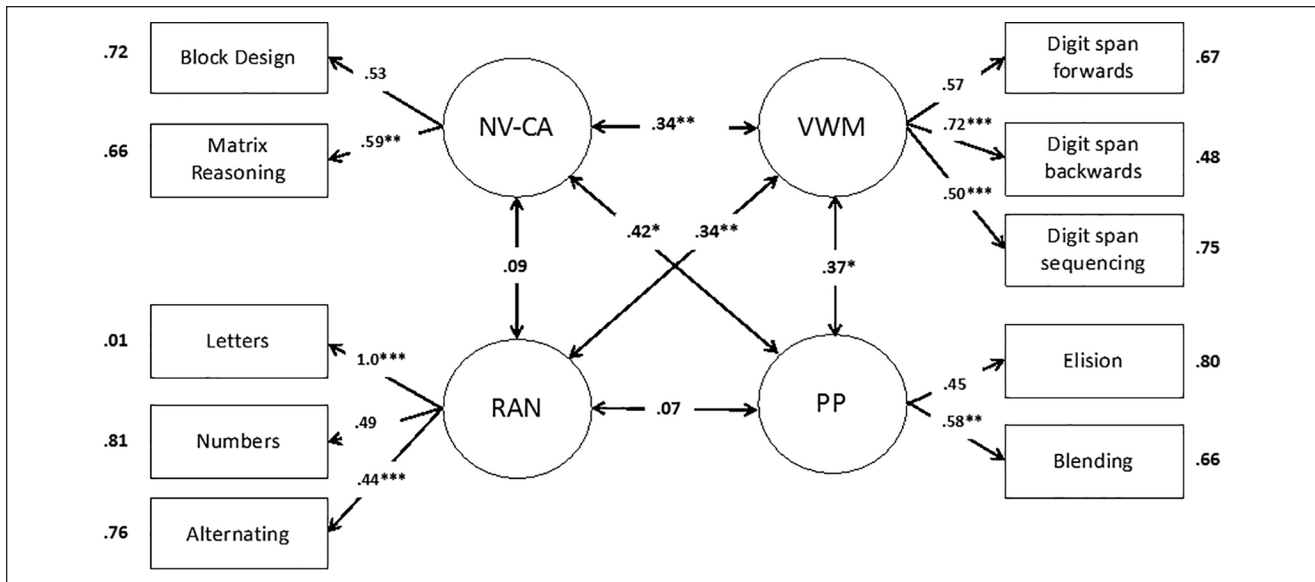

Figure A1. Diagram for the accepted measurement model with standardized solutions.

Note. NV-CA = nonverbal cognitive ability; block design, and matrix reasoning are subtests of the WASI (Wechsler, 1999). VWM = verbal working memory; digit span forward (DSF), digit span backward (DSB), and digit span sequencing (DSS) are subtests of the WAIS-IV (Wechsler, 2014). RAN = rapid automatized naming; numbers, letters, and the alternating are subtests of the RAN/RAS (Wolf & Denckla, 2005). PP: phonological processing; elision, blending, and nonword repetition (NWR) are subtests of the CTOPP (R. K. Wagner et al., 1999). Model fit indexes: $\chi^2 = 36.836$, $df = 29$, $p = .150$; comparative fit index (CFI) = .98, the Tucker–Lewis Index (TLI) = .97, and the root mean square error of approximation (RMSEA) = .030, 90% confidence interval (CI) = [0.000,0.056]. WASI = Wechsler Abbreviated Scale of Intelligence; WAIS-IV = Wechsler Adult Intelligence Scale–Fourth Edition.

*Statistically significant at .05 level. **Statistically significant at .01 level. ***Statistically significant at .001 level. All paths (except those for which the unstandardized estimates were restricted to 1) that specify the latent construct are statistically significant.

Author's Note

Stephanie Del Tufo is also affiliated with University of Delaware.

Acknowledgments

The data collection of this work was carried out at the University of Connecticut. The authors would like to thank Megan Speed and Jessica Joseph for rescoring standardized assessments, and Emily Fritzon for calculating point-to-point reliability. They also thank Kirstyn Collins, Emily Virok, and Ann Marie McKuhan for their assistance in checking the final version of the article for errors. Finally, they thank Emily B. Myers, under whose mentorship the two authors carried out the data collection activities that resulted in the present data set.

Declaration of Conflicting Interests

The author(s) declared no potential conflicts of interest with respect to the research, authorship, and/or publication of this article.

Funding

The author(s) disclosed receipt of the following financial support for the research, authorship, and/or publication of this article: This work was supported by an American Speech and Hearing Foundation scholarship and NIH NIDCD F31 DC014194 to F.S.E., and R01 DC013064 and faculty start-up funding from the University of Connecticut to Emily B. Myers. The content is the responsibility of the authors and does not necessarily represent the official views of the authors' funding sources.

ORCID iD

Stephanie N. Del Tufo  <https://orcid.org/0000-0002-2463-1785>

References

- American Psychiatric Association. (2013). *Diagnostic and statistical manual of mental disorders* (5th ed.). American Psychiatric Publishing.
- Archibald, L. M., & Gathercole, S. E. (2006). Short-term and working memory in specific language impairment. *International Journal of Language & Communication Disorders, 41*(6), 675–693. <https://doi.org/10.1080/13682820500442602>
- Baddeley, A. D., & Hitch, G. J. (1994). Developments in the concept of working memory. *Neuropsychology, 8*(4), 485–493. <https://doi.org/10.1037/0894-4105.8.4.485>
- Becker, T. C., & McGregor, K. K. (2016). Learning by listening to lectures is a challenge for college students with developmental language impairment. *Journal of Communication Disorders, 64*, 32–44. <https://doi.org/10.1016/j.jcomdis.2016.09.001>
- Best, J. R., Miller, P. H., & Naglieri, J. A. (2011). Relations between executive function and academic achievement from ages 5 to 17 in a large, representative national sample. *Learning and Individual Differences, 21*(4), 327–336.
- Bishop, D. V., Snowling, M. J., Thompson, P. A., Greenhalgh, T., & The CATALISE-2 consortium. (2017). Phase 2 of CATALISE: A multinational and multidisciplinary Delphi

- consensus study of problems with language development—Terminology. *Journal of Child Psychology and Psychiatry*, 58(10), 1068–1080. <https://doi.org/10.1111/jcpp.12721>
- Blair, C., & Razza, R. P. (2007). Relating effortful control, executive function, and false belief understanding to emerging math and literacy ability in kindergarten. *Child Development*, 78(2), 647–663. <https://doi.org/10.1111/j.1467-8624.2007.01019.x>
- Christodoulou, J. A., Del Tufo, S. N., Lymberis, J., Saxler, P. K., Ghosh, S. S., Triantafyllou, C., Whitfield-Gabrieli, S., & Gabrieli, J. D. E. (2014). Brain bases of reading fluency in typical reading and impaired fluency in dyslexia. *PLOS ONE*, 9(7), Article e100552.
- Cleave, P. L., Becker, S. D., Curran, M. K., Van Horne, A. J., & Fey, M. E. (2015). The efficacy of recasts in language intervention: A systematic review and meta-analysis. *American Journal of Speech-Language Pathology*, 24(2), 237–255.
- Clegg, J., Hollis, C., Mawhood, L., & Rutter, M. (2005). Developmental language disorders—A follow-up in later adult life. Cognitive, language and psychosocial outcomes. *Journal of Child Psychology and Psychiatry*, 46(2), 128–149.
- Conti-Ramsden, G., Durkin, K., Simkin, Z., & Knox, E. (2009). Specific language impairment and school outcomes. I: Identifying and explaining variability at the end of compulsory education. *International Journal of Language & Communication Disorders*, 44(1), 15–35.
- Daneman, M., & Carpenter, P. A. (1980). Individual differences in working memory and reading. *Journal of Verbal Learning and Verbal Behavior*, 19(4), 450–466.
- Denckla, M. B., & Rudel, R. G. (1976). Rapid “automatized” naming (R.A.N.): Dyslexia differentiated from other learning disabilities. *Neuropsychologia*, 14(4), 471–479.
- Diamond, A. (2013). Executive functions. *Annual Review of Psychology*, 64, 135–168.
- D’Mello, A. M., & Gabrieli, J. D. E. (2018). Cognitive neuroscience of dyslexia. *Language, Speech, and Hearing Services in Schools*, 49(4), 798–809. https://doi.org/10.1044/2018_LSHSS-DYSLC-18-0020
- Earle, F. S., Landi, N., & Myers, E. B. (2018). Adults with specific language impairment fail to consolidate speech sounds during sleep. *Neuroscience Letters*, 666, 58–63.
- Fidler, L. J., Plante, E., & Vance, R. (2011). Identification of adults with developmental language impairments. *American Journal of Speech-Language Pathology*, 20(1), 2–13.
- Fraser, J., & Conti-Ramsden, G. (2008). Contribution of phonological and broader language skills to literacy. *International Journal of Language & Communication Disorders*, 43(5), 552–569. <https://doi.org/10.1080/13682820701778069>
- Gabrieli, J. D. E. (2009). Dyslexia: A new synergy between education and cognitive neuroscience. *Science*, 325(5938), 280–283. <https://doi.org/10.1126/science.1171999>
- Gallinat, E., & Spaulding, T. J. (2014). Differences in the performance of children with specific language impairment and their typically developing peers on nonverbal cognitive tests: A meta-analysis. *Journal of Speech, Language, and Hearing Research*, 57(4), 1363–1382.
- Gathercole, S. E., Pickering, S. J., Knight, C., & Stegmann, Z. (2004). Working memory skills and educational attainment: Evidence from national curriculum assessments at 7 and 14 years of age. *Applied Cognitive Psychology*, 18, 1–16. <https://doi.org/10.1002/acp.934>
- Gioia, G. A., Isquith, P. K., Kenworthy, L., & Barton, R. M. (2002). Profiles of everyday executive function in acquired and developmental disorders. *Child Neuropsychology*, 8(2), 121–137. <https://doi.org/10.1076/chin.8.2.121.8727>
- Goswami, U., & Bryant, P. (2016). *Phonological skills and learning to read*. Routledge.
- Kapa, L. L., & Plante, E. (2015). Executive function in SLI: Recent advances and future directions. *Current Developmental Disorders Reports*, 2(3), 245–252.
- Katz, W. F., Curtiss, S., & Tallal, P. (1993). Naming and gesture by normal and language-impaired children: Evidence from a modified rapid automatized naming test. *Annals of the New York Academy of Sciences*, 682, 359–362.
- Keenan, J. M., Betjemann, R. S., & Olson, R. K. (2008). Reading comprehension tests vary in the skills they assess: Differential dependence on decoding and oral comprehension. *Scientific Studies of Reading*, 12(3), 281–300. <https://doi.org/10.1080/10888430802132279>
- Kim, Y. S., Wagner, R. K., & Lopez, D. (2012). Developmental relations between reading fluency and reading comprehension: A longitudinal study from grade 1 to grade 2. *Journal of Experimental Child Psychology*, 113(1), 93–111.
- Lee, J. (2011). Size matters: Early vocabulary as a predictor of language and literacy competence. *Applied Psycholinguistics*, 32(1), 69–92. <https://doi.org/10.1017/S0142716410000299>
- Lefly, D. L., & Pennington, B. F. (1991). Spelling errors and reading fluency in compensated adult dyslexics. *Annals of Dyslexia*, 41(1), 141–162. <https://doi.org/10.1007/BF02648083>
- Leonard, L. B. (2014). *Children with specific language impairment*. MIT Press.
- Lewandowski, L., Cohen, J., & Lovett, B. J. (2013). Effects of extended time allotments on reading comprehension performance of college students with and without learning disabilities. *Journal of Psychoeducational Assessment*, 31(3), 326–336.
- Lieberman, I. Y., Shankweiler, D., & Lieberman, A. M. (1989, October). *The alphabetic principle and learning to read* [Paper presentation]. Meeting of the International Academy for Research on Learning Disabilities, The University of Michigan Press, Evanston, IL, United States.
- Lyon, G. R., Shaywitz, S. E., & Shaywitz, B. A. (2003). A definition of dyslexia. *Annals of Dyslexia*, 53(1), 1–14. <https://doi.org/10.1007/s11881-003-0001-9>
- Madaus, J. W., & Shaw, S. F. (2006). The impact of the IDEA 2004 on transition to college for students with learning disabilities. *Learning Disabilities Research & Practice*, 21(4), 273–281. <https://doi.org/10.1111/j.1540-5826.2006.00223.x>
- McArthur, G. M., Hogben, J. H., Edwards, V. T., Heath, S. M., & Mengler, E. D. (2000). On the “specifics” of specific reading disability and specific language impairment. *The Journal of Child Psychology and Psychiatry and Allied Disciplines*, 41(7), 869–874.
- McGregor, K. K., Arbisi-Kelm, T., & Eden, N. (2017). The encoding of word forms into memory may be challenging for college students with developmental language impairment.

- International Journal of Speech-Language Pathology*, 19(1), 43–57.
- McGregor, K. K., Langenfeld, N., Van Horne, S., Oleson, J., Anson, M., & Jacobson, W. (2016). The university experiences of students with learning disabilities. *Learning Disabilities Research & Practice*, 31(2), 90–102. <https://doi.org/10.1111/ldrp.12102>
- Montgomery, J. W. (1995). Sentence comprehension in children with specific language impairment: The role of phonological working memory. *Journal of Speech, Language, and Hearing Research*, 38(1), 187–199. <https://doi.org/10.1044/jshr.3801.187>
- Morrison, F. J., Ponitz, C. C., & McClelland, M. M. (2010). Self-regulation and academic achievement in the transition to school. In S. D. Calkins & A. Bell (Eds.), *Child development at the intersection of emotion and cognition* (pp. 203–224). American Psychological Association.
- Mull, C., Sitlington, P. L., & Alper, S. (2001). Postsecondary education for students with learning disabilities: A synthesis of the literature. *Exceptional Children*, 68(1), 97–118.
- Munson, B., Kurtz, B. A., & Windsor, J. (2005). The influence of vocabulary size, phonotactic probability, and wordlikeness on nonword repetitions of children with and without specific language impairment. *Journal of Speech, Language, and Hearing Research*, 48(5), 1033–1047.
- Naha, N. M., Del Tufo, S. D., & Cutting, L. E. (2019). Learning lexical information depends upon task, learning approach, and reader subtype. *Journal of Learning Disabilities*, 52(6), 442–455.
- Nergård-Nilssen, T., & Hulme, C. (2014). Developmental dyslexia in adults: Behavioural manifestations and cognitive correlates. *Dyslexia*, 20(3), 191–207. <https://doi.org/10.1002/dys.1477>
- Newcomer, P. L., & Hammill, D. D. (2008). *Test of language development: Primary-4 (TOLD:P-4)*. Pro-Ed.
- Newman, L., Wagner, M., Knokey, A. M., Marder, C., Nagle, K., Shaver, D., Wei, X., Cameto, R., Contreras, E., Ferguson, K., Greene, S., & Schwarting, M. (2011). *The post-high school outcomes of young adults with disabilities up to 8 years after high school: A report from the National Longitudinal Transition Study-2 (NLTS2)* (NCSE 2011-3005). SRI International.
- Oldfield, R. C. (1971). The assessment and analysis of handedness: The Edinburgh inventory. *Neuropsychologia*, 9(1), 97–113. [https://doi.org/10.1016/0028-3932\(71\)90067-4](https://doi.org/10.1016/0028-3932(71)90067-4)
- Ramus, F., Marshall, C. R., Rosen, S., & van der Lely, H. K. (2013). Phonological deficits in specific language impairment and developmental dyslexia: Towards a multidimensional model. *Brain*, 136(2), 630–645. <https://doi.org/10.1093/brain/aws356>
- Ransby, M. J., & Swanson, L. H. (2003). Reading comprehension skills of young adults with childhood diagnoses of dyslexia. *Journal of Learning Disabilities*, 36(6), 538–555.
- Rasinski, T. V., Chang, S. C., Edmondson, E., Nageldinger, J., Nigh, J., Remark, L., Kenney, K. S., Walsh-Moorman, E., Yildirim, K., Nichols, W. D., Paige, D. D., & Rupley, W. H. (2017). Reading fluency and college readiness. *Journal of Adolescent & Adult Literacy*, 60(4), 453–460. <https://doi.org/10.1002/jaal.559>
- R Development Core Team. (2018). *R: A language environment for statistical computing*. Version 3.5.1. R Foundation for Statistical Computing. <https://www.R-project.org/>
- Rosseel, Y. (2012). lavaan: An R package for structural equation modeling. *Journal of Statistical Software*, 48(2), 1–36. <https://doi.org/10.18637/jss.v048.i02>
- Rost, G. C., & McGregor, K. K. (2012). Miranda rights comprehension in young adults with specific language impairment. *American Journal of Speech-Language Pathology*, 21(2), 101–108. [https://doi.org/10.1044/1058-0360\(2011/10-0094\)](https://doi.org/10.1044/1058-0360(2011/10-0094))
- Roth, R. M., Isquith, P. K., & Gioia, G. A. (2005). *Behavior rating inventory of executive function—Adult version [BRIEF-A]*. Psychological Assessment Resources.
- Royer, J. M., Abranovic, W. A., & Sinatra, G. M. (1987). Using entering reading comprehension performance as a predictor of performance in college classes. *Journal of Educational Psychology*, 79(1), 19–26. <https://doi.org/10.1037/0022-0663.79.1.19>
- Schatschneider, C., Fletcher, J. M., Francis, D. J., Carlson, C. D., & Foorman, B. R. (2004). Kindergarten prediction of reading skills: A longitudinal comparative analysis. *Journal of Educational Psychology*, 96(2), 265–282. <https://doi.org/10.1037/0022-0663.96.2.265>
- Shafir, U., & Siegel, L. S. (1994). Subtypes of learning disabilities in adolescents and adults. *Journal of Learning Disabilities*, 27(2), 123–134.
- Smith, E. E., & Jonides, J. (1999). Storage and executive processes in the frontal lobes. *Science*, 283(5408), 1657–1661. <https://doi.org/10.1126/science.283.5408.1657>
- Snowling, M. J. (2013). Early identification and interventions for dyslexia: A contemporary view. *Journal of Research in Special Educational Needs*, 13(1), 7–14.
- Snyder, T. D., de Brey, C., & Dillow, S. A. (2016). *Digest of Education Statistics 2014* (NCES 2016-006). U.S. Department of Education, Institute of Education Sciences, National Center for Education Statistics.
- Spearman, C. (1904). “General intelligence,” objectively determined and measured. *The American Journal of Psychology*, 15(2), 201–292. <https://doi.org/10.2307/1412107>
- Strenze, T. (2007). Intelligence and socioeconomic success: A meta-analytic review of longitudinal research. *Intelligence*, 35(5), 401–426.
- Suddarth, R., Plante, E., & Vance, R. (2012). Written narrative characteristics in adults with language impairment. *Journal of Speech, Language, and Hearing Research*, 55(2), 409–420.
- Svensson, I., & Jacobson, C. (2006). How persistent are phonological difficulties? A longitudinal study of reading retarded children. *Dyslexia*, 12(1), 3–20.
- Tomblin, J. B., Records, N. L., Buckwalter, P., Zhang, X., Smith, E., & O’Brien, M. (1997). Prevalence of specific language impairment in kindergarten children. *Journal of Speech, Language, and Hearing Research*, 40(6), 1245–1260.
- Torgesen, J. K., Rashotte, C. A., & Wagner, R. K. (1999). *Test of word reading efficiency (TOWRE)*. Pro-Ed.
- Vukovic, R. K., Wilson, A. M., & Nash, K. K. (2004). Naming speed deficits in adults with reading disabilities: A test of the double-deficit hypothesis. *Journal of Learning Disabilities*, 37(5), 440–450.

- Wagner, M., Newman, L., Cameto, R., Garza, N., & Levine, P. (2005). *After high school: A first look at the postschool experiences of youth with disabilities. A report from the National Longitudinal Transition Study-2 (NLTS2)*. SRI International.
- Wagner, R. K., Torgesen, J. K., & Rashotte, C. A. (1994). Development of reading-related phonological processing abilities: New evidence of bidirectional causality from a latent variable longitudinal study. *Developmental Psychology*, *30*(1), 73–87.
- Wagner, R. K., Torgesen, J. K., & Rashotte, C. A. (1999). *Comprehensive test of phonological processing (CTOPP)*. Pro-Ed.
- Wechsler, D. (1999). *Wechsler Adult Intelligence Scale of Intelligence*. Harcourt Assessment.
- Wechsler, D. (2008). *Wechsler Adult Intelligence Scale—Fourth edition (WAIS-IV)*. Psychological Corporation.
- Weis, R., Dean, E. L., & Osborne, K. J. (2016). Accommodation decision making for postsecondary students with learning disabilities: Individually tailored or one size fits all? *Journal of Learning Disabilities*, *49*(5), 484–498.
- Wetherell, D., Botting, N., & Conti-Ramsden, G. (2007). Narrative in adolescent specific language impairment (SLI): A comparison with peers across two different narrative genres. *International Journal of Language & Communication Disorders*, *42*(5), 583–605.
- Wolf, M. (1986). Rapid alternating stimulus naming in the developmental dyslexias. *Brain and Language*, *27*(2), 360–379.
- Wolf, M., & Denckla, M. B. (2005). *Rapid automatized naming and rapid alternating stimulus rests (RAN/RAS)*. Pro-Ed.
- Woodcock, R. W. (2011). *Woodcock reading mastery tests—Third edition (WRMT-III)*. Pearson Education.
- Woodcock, R. W., McGrew, K. S., & Mather, N. (2001). *Woodcock-Johnson III tests of achievement (WJ-III)*. Riverside.
- Ziegler, J. C., Pech-Georgel, C., George, F., Alario, F. X., & Lorenzi, C. (2005). Deficits in speech perception predict language learning impairment. *Proceedings of the National Academy of Sciences*, *102*(39), 14110–14115