

The Electronic Tabla Controller¹

Ajay Kapur¹, Georg Essl², Philip Davidson¹ and Perry R. Cook^{1,3}

Departments of ¹Computer Science and ³Music, Princeton University, Princeton, NJ, USA and ²Computer & Information Science & Engineering Department, University of Florida, Gainesville, FL, USA

Abstract

This paper describes the design of an electronic Tabla controller (ETabla). Tabla are a pair of hand drums traditionally used to accompany North Indian vocal and instrumental music. The ETabla controls both sound and graphics simultaneously. It allows for a variety of traditional Tabla strokes and new performance techniques. Graphical feedback allows for artistic display and has potential pedagogical applications. This paper describes the evolution of the technology of the Tabla from its origins until the present day; the traditional playing style of the Tabla, on which the controller is modeled; the creation of a real-time Tabla controller, using force-sensors; the physical modeling of the sound of the Tabla using banded waveguide synthesis; the creation of a real-time graphics feedback system that reacts to the Tabla controller; experiments on measuring the response time of the ETabla sensors; and the description of the ETabla used in a live performance.

1. Introduction

Tabla are a pair of hand drums traditionally used to accompany North Indian vocal and instrumental music. The silver, larger drum (shown in Fig. 1) is known as the *Bayan*. The smaller wooden drum is known as the *Dahina* (Courtney, 1995). The pitch can be tuned by manipulating the tension on the *pudi* (drumhead). The Bayan is tuned by adjusting the tightness of the top rim. The Dahina can be tuned similarly, as well as by adjusting the position of the cylindrical wooden pieces on the body of the drum. Tabla are unique because the drumheads have weights at the center made of a paste of iron oxide, charcoal, starch, and gum (round, black spots shown in the Figures) (Rossing, 1999). Also, the Tabla make a myriad of different sounds by the many different ways it is stroked. These strokes follow a tradition that has been passed

on from generation to generation, from *guru* (teacher, master) to *shikshak* (student) in the country of India. The combination of the “weighting” of the drum-head, and the variety of strokes by which the Tabla can be played, gives the drum a complexity that makes it a challenging controller to create, as well as a challenging sound to simulate. In the remainder of this paper, we will present:

- The evolution of the technology of the Tabla from its origins until the present day.
- The traditional playing style of the Tabla, on which the controller is modeled.
- The creation of a real-time Tabla controller, using force-sensors.
- The physical modeling of the sound of the Tabla using banded waveguide synthesis.
- The creation of a real-time graphics feedback system that reacts to the Tabla controller.
- The experiments on measuring response time of the ETabla sensors.
- The description of the ETabla used in a live performance.

2. Evolution of the Tabla

There are a few accounts for the origin of the Tabla. A mythological account reads: “Once, a long time ago, during the transitional period between two Ages . . . people took to uncivilized ways . . . ruled by lust and greed [as they] behaved in angry and jealous ways, [while] demons, [and] evil spirits . . . swarmed the earth. Seeing this plight, Indra (The Hindu God of thunder and storms) and other Gods

¹A preliminary version of this work has been reported in Kapur et al. (2002).

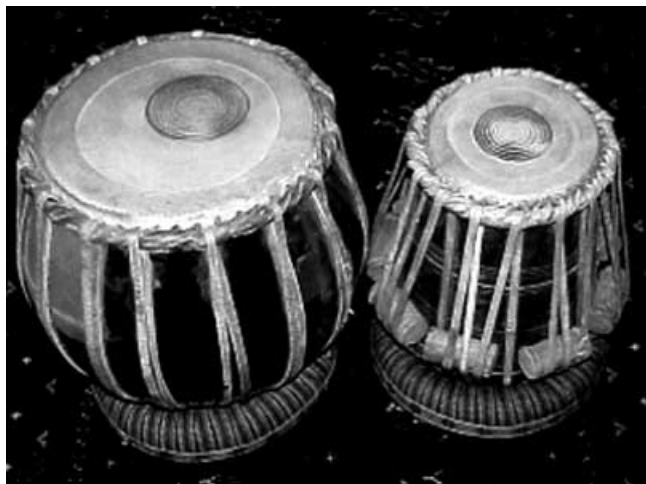

Fig. 1. Picture showing North Indian Tabla. The Bayan is the silver drum on the left. The Dahina is the wooden drum on the right.



Fig. 2. Picture showing a Mridangam, a drum of the Pakhawaj family.

approached God Brahma (God of creation) and requested him to give the people a Krindaniyaka (toy) . . . which could not only be seen, but heard, . . . [to create] a diversion, so that people would give up their bad ways” (Courtney, 1995). One of the Krindaniyakas, which Brahma gave to humans was the Tabla. Other legends state that the Tabla was created in the 18th Century by Sidhar Khan Dhari, a famous Pakhawaj player. Pakhawaj is a genre of Indian drum defined by a barrel with drum-heads on either side. The *Mrindangam*, shown in Figure 2, is one drum in this family of drums. It was said that Sidhar Khan provoked an angry dispute after losing a music contest and his Pakhawaj was chopped in half by a sword. Thus, the first Tabla was created accidentally (Deva, 1974). It is possible that the Tabla is related to drum pairs of the antiquity, though references in old music texts completely disappeared after the 10th century (Sanyal, 1985). Some Tablas were created out of clay, others out of wood. As technology for producing metal alloys evolved, the



Fig. 3. Picture showing parts of Tabla pudi.

Bayan started to be molded out of brass and steel (Courtney, 1993).

As the popularity of the Tabla spread to the western hemisphere, nearly coincident with emergence of the personal computer, people began to combine the Tabla with computers. In 1992, James Kippen created software that allowed a user to input a traditional Tabla rhythmic pattern, which the computer would then use to synthesize an improvised pattern that followed traditional rules for variation (Kippen, 1992). In 1998, Mathew Wright and David Wessel of University of California Berkeley, aimed to achieve a similar goal, with a real time interface and unique data structure. They successfully created software that generated “free and unconstrained” music material, which could fit into a given traditional rhythmic structure (Wright & Wessel, 1998). Jae Hun Roh and Lynn Wilcox created two pressure sensitive pads to input rhythms. These patterns are then used to generate new phrases based on traditional Tabla patterns (Roh, Jun, & Wilcox, 1995). Meanwhile, Talvin Singh created a direct input from his Tabla to computer effects, achieving sound manipulations in an invention he calls “Tablatronics” (Kaul, 1998).

There are a number of commercially available hand-drum controllers such as Buchla’s Thunder,² Korg’s WaveDrum,³ and Roland’s HandSonic.⁴ The ETabla project, however, uses a new physical model of Tabla acoustics. Our main goal is to preserve the traditional appearance, feel, and performance characteristics of North Indian classical Tabla drumming, while electronically extending the variety of sounds available to the player.

3. Tabla strokes

It is important to understand the traditional playing style of the Tabla to see how our controller models its hand movement. Figure 3 is a picture explaining the names of the different parts of the Tabla *pudi* (drum head).

² Available at: <http://www.buchla.com/historical/thunder/>

³ Available at: <http://www.korg.com>

⁴ Available at: <http://www.rolandus.com/pdf/roland/HPD-15.pdf>



Fig. 4. Pictures showing traditional strokes played on Bayan.

3.1 Bayan strokes

There are two strokes played on the Bayan. The *Ka* stroke is executed by slapping the flat left hand down on the Bayan as shown in Figure 4(a). Notice the tips of the fingers extend from the *maidan* through to the *chat* and over the edge of the drum. The slapping hand remains on the drum after it is struck to kill all resonance, before it is released away. The *Ga* stroke, shown in Figure 4(b), is executed by striking the *maidan* directly above the *syahi* with the middle and index fingers of the left hand. When the fingers strike, they immediately release away from the drum, to let the Bayan resonate with sound. The heel of the left hand controls the pitch of the *Ga* stroke, as shown in Figure 4(c). It controls the pitch at the attack of the stroke, and can also bend the pitch while the drum is resonating. Pitch is controlled by two variables of the heel of the hand: force on to the *pudi*, and the position of the hand-heel on the *pudi* from the edge of the *maidan* and *syahi* to the center of the *syahi*. The greater the force on the *pudi*, the higher the pitch. The closer to the center of the *syahi*, the higher the pitch (Courtney, 1995).

3.2 Dahina strokes

There are six main strokes played on the Dahina. The *Na* stroke, shown in Figure 5(a), is executed by lightly pressing the pinky finger of the right hand down between the *chat* and the *maidan*, and lightly pressing the ring finger down between the *syahi* and the *maidan* in order to mute the sound of the drum. Then one strikes the *chat* with the index finger and quickly releases it so the sound of the drum resonates. The *Ta* stroke is executed by striking the middle finger of the right hand at the center of the *syahi*, as shown in Figure 5(b). The finger is held there before release so there is no resonance, creating a damped sound. The *Ti* stroke, shown in Figure 5(c), is similar to *Ta* except the middle and ring finger of the right hand strike the center of the *syahi*. This stroke does not resonate and creates a damped sound. The *Tu* stroke is executed by striking the *maidan* with the index finger of the right hand and quickly releasing, as shown in Figure 5(d). This stroke resonates the most because the pinky and ring fingers are not muting the *pudi* (Courtney,

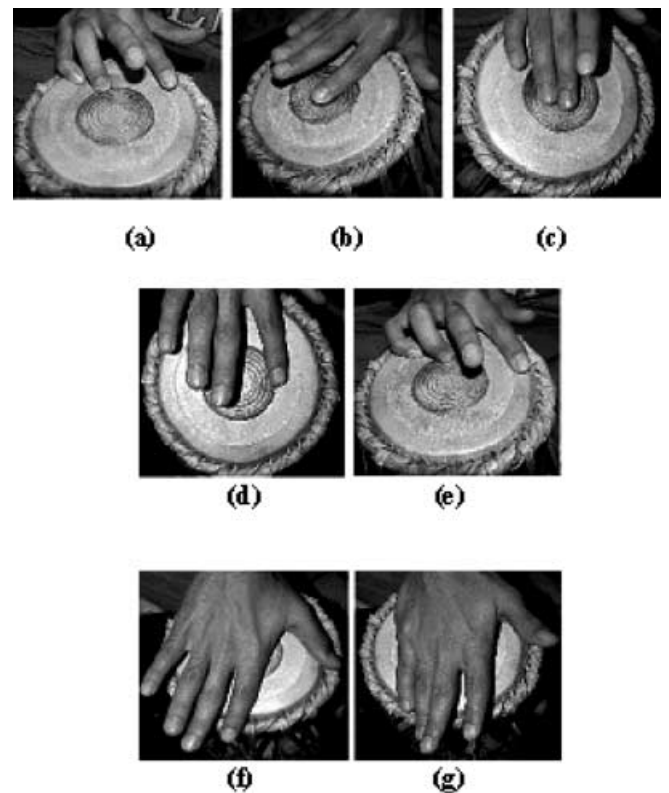

Fig. 5. Picture showing traditional strokes played on the Dahina.

1995). The *Tit* stroke, shown in Figure 5(e), is executed similar to *Na*, by lightly pressing the pinky finger of the right hand down between the *chat* and the *maidan*, and lightly pressing the ring finger down between the *syahi* and the *maidan*. The index finger then strikes the *chat*, quickly releasing to let it resonate. The index finger strike on the *chat* is further away from the pinky and ring finger, than it is on the *Na* stroke. *Tira* is a combination of two strokes on the Dahina, which explains the two syllables of the stroke. It is executed by shifting the entire right hand from one side of the drum to the other. It creates a damped sound at each strike. This stroke is shown in Figure 5(f) and Figure 5(g).



Fig. 6. Picture showing Bayan controller FSR layout.

4. The MIDI Tabla Controller

We modeled our controller based on the hand positioning and movements of the strokes discussed. Note that our interest was not specifically to simply copy the traditional Tabla (“[just] copying an instrument is dumb, leveraging expert technique is smart” (Cook, 2000)), but rather the actual goal of this project was to make an instrument that could be used to create an audio and visual experience that allows performer expression, and enamors the audience. The ETabla is decoupled from the computer generated sound source and hence achieves a new versatility while preserving the refined performance practices of traditional play. To leverage the existing technique of a skilled Tabla player and to actually test the instrument we decided it would be important to work with an expert traditional Tabla player. We decided that the ETabla needed to support traditional strokes accurately. We used square force sensing resistors (square FSR) to input force of different finger strikes, and long force sensing resistors (long FSR) to obtain the position of finger strikes, as well as force.⁵ All events are converted to MIDI signals and sent out via a MIDI output.

4.1 The Bayan Controller

The Bayan Controller was created using two square FSRs, and one long FSR. Figure 6 shows a layout of these FSRs. The top square FSR is used to capture *Ka* stroke events, when a player slaps down with their left hand. If it receives a signal,

then the other two FSRs are ignored. The square FSR in the middle, captures *Ga* stroke events, when struck by the middle and index finger of the left hand. The long FSR controls the pitch of the *Ga* stroke events, using two variables: force and position. The greater the force exerted by the heel of the left hand, the higher the pitch. The closer the heel of the hand gets to the *Ga* FSR, the higher the pitch. The pitch can be bent after a *Ga* stroke is triggered. The circuit diagram of the Bayan controller is shown in Figure 7.

4.2 The Dahina Controller

To implement the Dahina Controller, we used four FSRs: two long FSRs, one square FSR, and one small FSR. Figure 8 shows a layout of these FSRs. The small FSR triggers a *Tit* stroke event. It measures the velocity of the index finger’s strike. The square FSR triggers a *Tira* stroke event. It measures the velocity of the hand slapping the top of the drum. If the *Tira* FSR is struck, all other FSRs are ignored. If the *Tit* FSR is struck, both long FSRs are ignored. The long FSR on the right in Figure 8 is the ring finger FSR, and the long FSR on the left is the index finger FSR. If there is a little force on the ring finger FSR (modeling a mute), and the index finger FSR is struck at the edge of circle, a *Na* stroke is triggered. If the index finger FSR is struck near the center of the circle, a *Ta* stroke is triggered. If there is no force on the ring finger FSR, and the index finger FSR is struck, then a *Tu* stroke is triggered. When the ring finger FSR is struck with enough force, and not held down, then a *Ti* stroke is triggered. The circuitry of this controller uses similar logic to that of the Bayan. Thus we have modeled every stroke that we discussed above. Figure 9 shows a picture of both controllers in their constructed Tabla encasements.⁶ The force sensing resistor were placed on top of custom built wood pieces, and covered with neoprene as a protective layer, making the instrument acoustically quiet, and providing a flexible texture for ETabla performance.

5. Sound simulation

The electronic Tabla controller signals can be used with any standard MIDI device to produce sound. However, the typical synthesis methods do not properly mimic the dynamics of the Tabla drums and hence the performance sound in relation to strokes is not well captured. Physical modeling is known to allow for direct physical interactions and hence the control values produced by the Tabla controller can be directly used as inputs rather than first finding a mapping that relates controller-output to synthesis-relevant parameters. We use the “banded waveguides” which were originally introduced for one-dimensional structures like bar percus-

⁵ Available at: <http://www-ccrma.stanford.edu/CCRMA/Courses/252/sensors/sensors.html>

⁶ The wood pieces were custom built by Brad Alexander at County Cabinet Shop in Princeton, NJ.

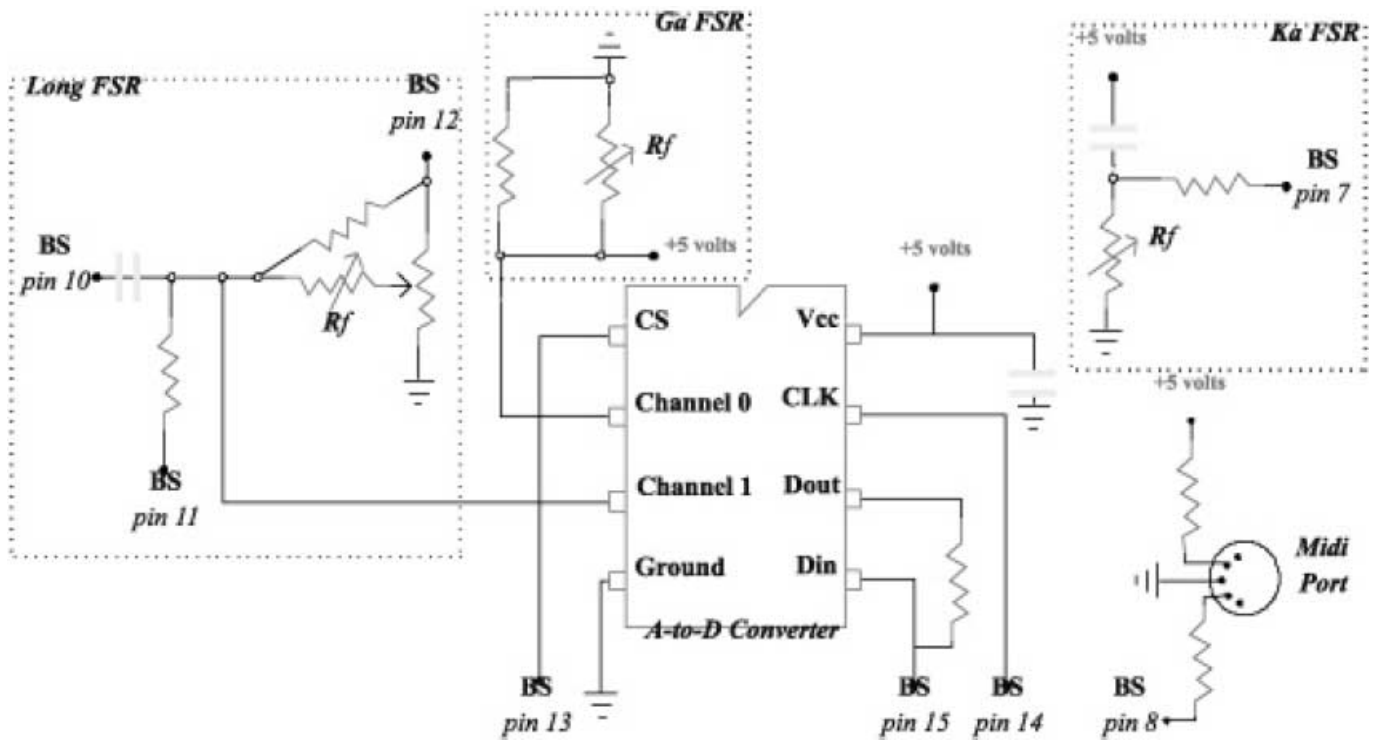

Fig. 7. Circuit diagram of Bayan Controller. The Dahina Controller uses similar logic.

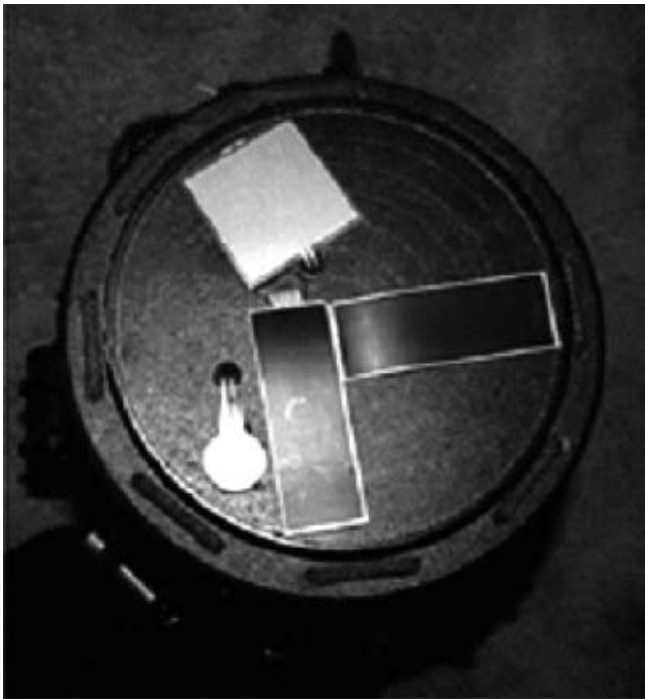

Fig. 8. Picture showing Dahina controller FSR layout.



Fig. 9. The Electronic Tabla Controller.

sion instruments (Essl & Cook, 1999) but has recently been generalized to higher-dimensional structures including membranes (Essl, 2002). Here we will discuss only essential features of the ideas as they pertain to the Etabla controller and

the reader is referred to Essl (2002) for a more detailed discussion of the synthesis method.

Banded waveguides are a generalization of digital waveguide filters (Smith, 2002) that accommodate complex

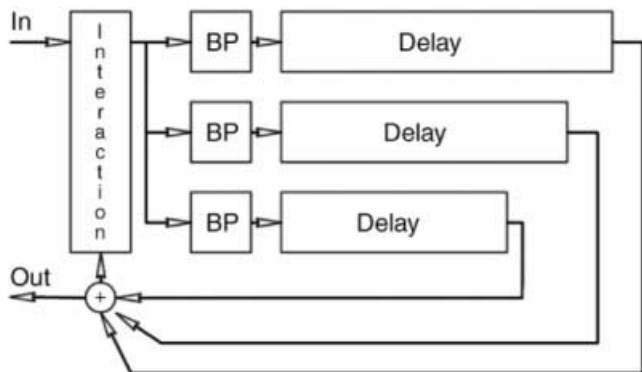

Fig. 10. Figure showing banded waveguide schematic.

material behavior and higher dimensions by modeling the traveling waves for each modal frequency separately as is depicted in Figure 10.

Modes come about as standing waves, which is equivalent to the condition that traveling waves close onto themselves in phase. Hence the task of finding geometric positions from modes corresponds to finding paths that close onto themselves and finding the matching mode for that path. This problem has been studied by Keller and Rubinow (Keller & Rubinow, 1960) and the construction of finding these paths on a circular membrane is depicted in Figure 11. We have taken these paths as approximate representations as they were constructed for uniform membranes. Tabla membranes are non-uniform and heterogeneous in material. The effect of these non-uniformity is the tuning of the partials to harmonic ratios. The physical effect of the successive loading of the membrane lowers the frequencies of the partials (Fletcher & Rossing, 1998). This is equivalent to a slower propagation speed in the medium. Alternatively this can be viewed as a virtual lengthening of the closed path lengths of modes. The effect is modeled in this fashion in banded waveguides.

Tabla strokes correspond to feeding strike-velocities into the delay lines at the correct positions. A particularly interesting performance stroke is the *Ga* stroke performed on the Bayan depicted in Figure 4(c). It includes a pitch bend that is achieved by modifying the vibrating area due to pushing forward. The exact dynamical behavior of this interaction is so far unknown. We make the simplified assumption that this can be viewed as a moving boundary, which in the case of banded waveguides corresponds to a shortening of the closed wavepaths, in turn corresponding to a shortening of the delay-lines of the model. The stroke starts at about 131 Hz (C-3) and ends at about 165 Hz (E-3) and hence corresponds to a 26% pitch increase and banded wavepath shortening. The simulation was implemented in C++ on a commodity PC and runs at interactive rates. A comparison of a recorded and a simulated *Ga* stroke can be seen in Figure 12. Both strokes are qualitatively similar and are judged by the listeners to be perceptually close. Since banded waveguides are based on standard linear waveguide filters theory, we can make the sonic model as accurate (or absurd) as we like.

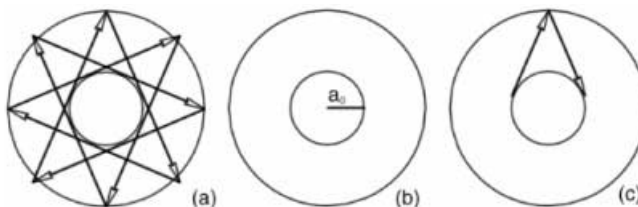

Fig. 11. Figures showing construction of paths that close onto themselves.

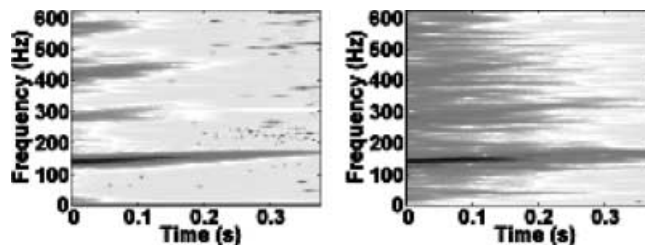

Fig. 12. Sonograms comparing recorded (left) and simulated (right) *Ga* strike.

6. Graphic feedback

The visual system for the electronic Tabla is designed to augment the experience of the electronic Tabla for both and audience through the generation of a visual display which responds in parallel with the aural elements of the system. Since audio synthesis requires most of the processing power on the audio machine, control messages from the Tabla are routed to a second machine for graphics processing, using custom software built in C++/OpenGL. We will describe the response of the system to Bayan strikes.

For the concert performance, our concept for the graphics system was a combination of geometric forms and fluid motion. To respond to the percussive energy of Tabla music, the visualization we developed is based on a particle model in which strikes made by the player appear as patterns of small shapes, which form the basic visual elements of the display. As the player makes *Ka* and *Ga* strikes on the Bayan controller, particle bursts appear as lines, circles, cardioids, and other shapes depending on the type and quality of each strike as transmitted by the drum. Velocity and pitch are mapped to the size, color, complexity and physical characteristics of the patterns we create. Additional control messages can be sent to the system by another performer to modify the mapping of tabla signals to visual response as the performance progresses. Once created, the motion of these particles is governed by a dynamically changing vector field that imposes forces on each particle to achieve a particular overall effect. Strike particles appear, break apart, and return into the background. The behavior of the field is governed by a distribution of “cells” which determine how forces are exerted in their vicinity, in response to the number, distribution, and motion of particles in their domain (Stam & Fiume, 1993). Through the feedback of cell-particle dynamics, we

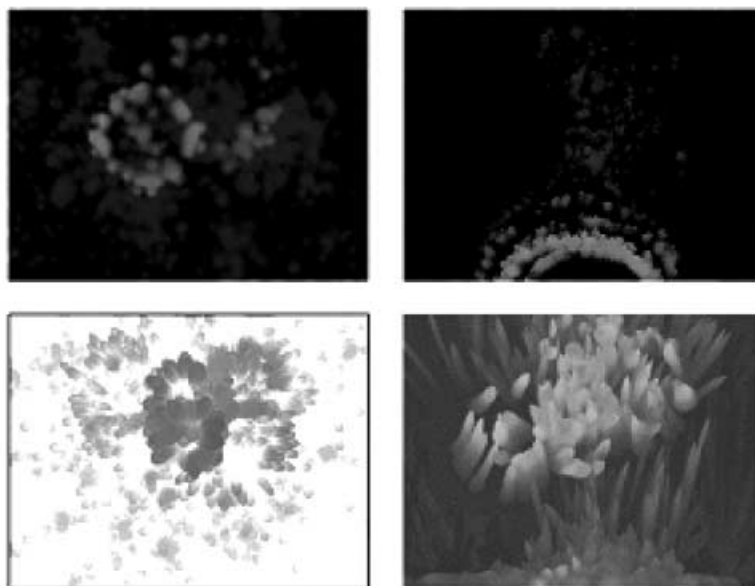

Fig. 13. Different modes of visual feedback.

obtain a system with a short and long term visual response, as the energy introduced by tabla strikes excites secondary behavior in the physical system. By properly modifying the characteristics of particles and cell response behaviors, we can evoke an impression of real-world systems: fanning a flame, striking the surface of water, blowing leaves, or other more abstract behaviors (see Fig. 13).

Feedback from users of the ETabla commented that they would sometimes choose to “play” the visuals using the controller, which is an interesting reversal of our expectation – that perhaps the visual feedback should lead the performer towards playing certain rhythms. We have also modified the software to provide a richer visual vocabulary. Beyond its use in performance, visual feedback is also helpful to display the state of our virtual drum. Though the Bayan is responsive to changes in tension on the head of the drum, our physical controller does not provide this degree of response. However, we may create the sense of an increase or decrease in tension on the drumhead through compressive or decompressive effects to the visual system. As a teaching tool, the system could display the names and hand positions for the various strikes being made, so that a novice user could reinforce their knowledge and correct their technique. This is an area for future research and implementation.

7. Tests of the ETabla sensors

We administered three experiments on measuring the response time of the ETabla sensors. We recruited a musician who has been playing Tabla for 10 years as our unbiased ETabla user who we tested throughout the development process. In the first test the player simply tried to trigger the eight basic traditional Tabla strokes discussed above. He suc-

cessfully was able to trigger all the strokes, but with a noticeable margin of error. We hypothesized that the errors occurred because at this point the ETabla was not mechanically reliable, as the sensors were simply taped to a slab of wood and a piece of cardboard which were simply sitting on top of a Tabla shell, without enough support to sustain reliable play. The results of this first battery of tests was sufficient, however, to verify that we had put the sensors in the right places, and a trained Tabla player could execute the strokes, even though he was not specifically trained on the ETabla.

After we had successfully created a secure system for encasing the circuit boards and fastening the sensors to the ETabla body, using custom built wood pieces, we performed a second round of user tests (A on Fig. 14). We measured the response time of each sensor on the EDahina (the right hand drum of the ETabla). A metronome was used to measure the maximum rate at which one would strike a particular FSR before it became unreliable. We connected the MIDI Out messages produced by the ETabla to the Roland HandSonic. The tester was asked to perform one strike per metronome click. The metronome speed was increased as long as there was a sound response without immediate problems. Figure 14 is a chart showing the response times of the EDahina by stroke in comparison with a later test. From this user test, it was clear that the two position-only FSRs were responding well. However, the long linear position FSRs were running too slow. This was because the force variable for the long FSR was captured through a slower data acquisition process. We also felt that the Ring Finger FSR was not calibrated correctly in the code and thus finger strike responses were difficult to pick up.

To solve these timing problems, an upgrade of the microprocessor was carried out, yielding a system that could

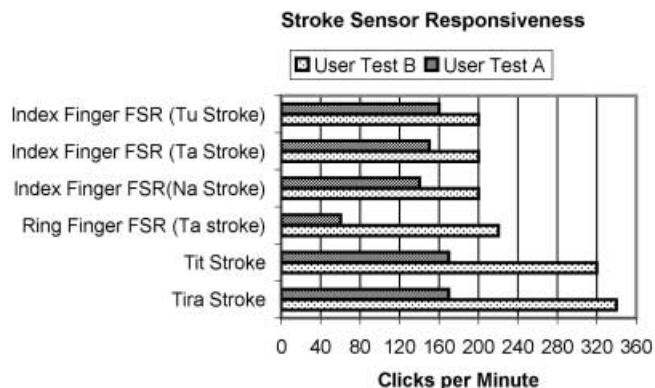

Fig. 14. User testing results of the ETabla of User Test A and B. The tests measured maximum strike rate for each sensor as evaluated by an expert performer.

execute commands 2.5 times faster.⁷ In user test B, Our tester was successfully able to play a recognizable Tin Taal rhythm, a traditional 16 beat Tabla cycle, at a moderate tempo. He then tested the response time of the EDahina. Figure 14 also shows the results of his tests. Once again, metronome speed was successively increased as long as the tester at the given speed achieved a sound response without immediate problems. The *Ta* stroke on the Ring Finger FSR was the slowest for this second user test, only being able to be hit at 60 beats per minute. With the new upgrade, the ETabla could now do the same stroke 3.5 times faster at 220 beats per minute. The improvement can be clearly seen in Figure 14. The *Tira* and *Tit* strokes were very fast and were acceptable for performance. The next goal was to raise every stroke close to this level. The tester complained that the two long FSRs were generally difficult to strike and get an immediate response. We knew we could fix this with recalibration. The tester also recommended that the edge of the Index Finger FSR should always play a *Na* stroke and the center should always play a *Tu* stroke. This improvement made the response time much faster.

The remaining improvements to the responsiveness were carried by carefully optimizing the microcontroller code. By some reordering of execution, it was ensured that no mathematical manipulation of variables occurred unless they were needed to for a particular event. Wherever possible, divide and multiply operations were converted to shift right and left shift operations to save instruction time. After these improvements were tested, the behavior of the ETabla was up to the desired performance, and we were ready to use the ETabla in a live concert setting.



Fig. 15. The ETabla in a live concert. Taplin Auditorium, Princeton University, April 25, 2002.

8. ETabla in live performance

One of the goals of this project was to make an instrument that can actually be used to create an audio and visual experience that expresses the feelings of the performer and enamors the audience. The premier performance of the Electronic Tabla was held on April 25th, 2002 in Taplin Auditorium, Princeton University. Princeton undergraduate and graduate students joined faculty members and alumni in a concert mixing music from India, Africa and modern America, with electronic grooves and beats. Video clips can be found in the online JNMR Electronic forum⁸ (see Fig. 15).

The ETabla premiered in a traditional North Indian classical song playing a Tin Taal, a traditional rhythmical cycle of 16 beats. The ETabla was also featured in a song with an artist playing the Roland GrooveBox, an instrument that by it's nature very accurately keeps time. The playability of the ETabla easily held up in performance with the rhythmically precise drum machine. Another piece of the concert was the "Dissonance Ritual," where the ETabla created atmospheric sound-scapes, triggering long lasting electronic samples. From the nights performance, the practical usability of the ETabla was demonstrated in accompanying compositions in a variety of musical genres. Those in the audience gave informal positive feedback on the visual feedback system projected on a screen behind the performers, as well as the switch between traditional Indian Tabla sounds and the novel electronic sounds that the ETabla could trigger.

⁷Upgrade from Basic StampII to Basic StampIIsx, BASIC Stamp Programming Manual. version 2.0. Parallax Inc. Available at www.parallaxinc.com

⁸Links to ETabla concert video clips are available in Online Appendix.

9. Conclusion

We presented the ETabla, a real-time device for Tabla performance. Its design was motivated by the traditional instrument and the design takes classical stroke styles into account. We demonstrated how an implementation can be achieved that allows for the use of the ETabla in live performance, allowing for traditional performance style, but also augmenting the traditional interactions in various ways. The interaction and sound production mechanism have been decoupled. The performer can now choose the sound production, independent of the physical interaction. Hence, non-standard sounds and alternative musical expressions can be achieved while maintaining the performance expression of the traditional Tabla interaction. In addition this decoupling allows for performance input to drive output in other modalities. We illustrate this ability by providing performance-dependent visual feedback. In concert, this visual feedback has been used as visual background for performed musical pieces. Similar visual feedback could, however, also be used for teaching purposes by lending additional cues to the student. This aspect remains to be explored in detail. Another interesting future application is the use of the ETabla to record performance styles of expert tabla players. This information could be used to facilitate teaching of novice players and the study of classical Indian drumming styles.

Acknowledgements

Our thanks to Manjul Bhargava for his Tabla playing and ETabla testing. Thanks to David Hittson for photographing Tabla strokes. Special thanks to Brad Alexander for helping design custom wood pieces for the ETabla. Many thanks to all those who helped fund this project including: Chair Professor Scott Burnham of the Princeton University Music Department, Chair David Dobkin of the Princeton University Computer Science Department, Dean Peter Bogucki of the Princeton University Engineering School, Princeton University President Harold T. Shapiro, Princeton University President Shirley M. Tilghman, Princeton University Vice President of Student Life Janet S. Dickerson, and Arun & Meera Kapur. We are also grateful for the comments of three anonymous reviewers which greatly improved the manuscript.

References

Cook, P.R. (2001). Principles for designing computer music controllers [On-line]. NIME 2001, ACM CHI 2001 Workshop.

- Seattle WA. Available: <http://www.csl.sony.co.jp/person/poup/research/chi2000wshp/papers/cook.pdf>
- Courtney, D.R. (1993). Repair and maintenance of tabla. *Percussive Notes*, 31, 29–36.
- Courtney, D.R. (1995). Fundamentals of tabla: Complete reference for Tabla. vol. 1, Houston TX:Sur Sangeet Services, 1–15.
- Deva, B.C. (1974). *Indian music*. New Delhi: Indian Council for Cultural Relations.
- Essl, G., & Cook, P.R. (1999). Banded Waveguides: Towards Physical Modeling of Bar Percussion Instruments. In *Proceedings of the International Computer Music Conference (ICMC)*, Beijing, China, 321–324.
- Essl, G. (2002). *Physical Wave Propagation Modeling for Real-Time Synthesis of Natural Sounds*. Ph.D. Thesis, Computer Science Department, Princeton University, November 2002.
- Fletcher, N.H., & Rossing, T.D. (1998). *The physics of musical instruments*. Second Edition. New York: Springer Verlag.
- Kapur, A., Essl, G., Davidson, P., & Cook, P.R. (2002). The Electronic Tabla Controller. In *Proceedings of the 2002 Conference on New Instruments for Musical Expression (NIME-02)*, Dublin, Ireland, 77–81.
- Kaul, V. (1998). Talvin Singh [On-line]. Available: <http://www.india-today.com/ttoday/121998/boom.html>
- Keller, J.B., & Rubinow, S.I. (1960). Asymptotic solution of eigenvalue problems. *Annals of Physics*, 9, 24–75.
- Kippen, J. (1992). Tabla drumming and the human-computer interaction. *The World of Music*, 34, 72–98.
- Roh, J.H., & Wilcox, L. (1995). Exploring tabla using rhythmic input. In *Proceeding of the CHI '95*. Denver, CO, 310–311.
- Rossing, T.D. (1999). *The science of sound*. 373–4. Addison-Wesley Publishing Company.
- Sanyal, R. (1985). Musical instruments: The Indian approach. In *Classical Music of India. Festival of India 1985–1986*. Sangeet Research Academy, 31–34.
- Smith, J.O. (2002). Digital Waveguide Modeling of Musical Instruments [On-line]. Center for Computer Research in Music and Acoustics (CCRMA), Stanford University, 2002-09-25. Available: <http://www-ccrma.stanford.edu/~jos/waveguide/>
- Stam, J., & Fiume, E. (1993). Turbulent Wind Fields for Gaseous Phenomena. In *SIGGRAPH '93 Conference Proceedings, Annual Conference Series*, 369–376.
- Wright, M., & Wessel, D. (1998). An Improvisation Environment for Generating Rhythmic Structures Based on North Indian “Tal” Patterns. Available: <http://cnmat.cnm.berkeley.edu/ICMC98/papers-html/wright-wessel-tal-demo.html>