

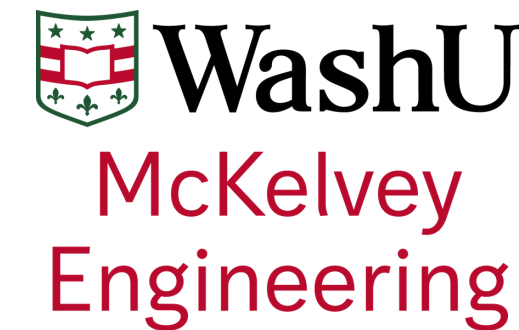

# GS-1

## A UHF Ground Station for LEO Satellite Communication

WashU Satellite Team



### Introduction

To communicate with our future satellites, WashU Satellite needed an in-house built UHF (Ultra-High Frequency) ground station antenna. GS-1 consists of 3.5m circularly polarized Yagi-Uda antenna, an azimuth and elevation rotator, an SDR (software defined radio) and a frame to hold it all. It is designed to operate in rooftop outdoor conditions indefinitely, including up to 90mph winds, rain, and snow.

### Structure

The ground station uses all aluminum, PVC, and galvanized steel parts for weather resistance. It also has space to support up to 400kg of ballast in the form of cinderblocks

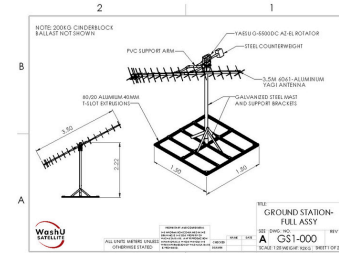

Engineering Drawing of GS-1

### Software Block Diagram

The ground station employs a custom packetization & communication pipeline built off of industry-tested CCSDS standards.

All data received from the satellite in the form of telemetry and response packets are saved to persistent storage and visualized by an array of connected client dashboards. These dashboards, web applications which employ Grafana and ReactJS, create a rich environment for data visualization and command synthesis, and act as the user-facing endpoint of the ground station for end-to-end communication

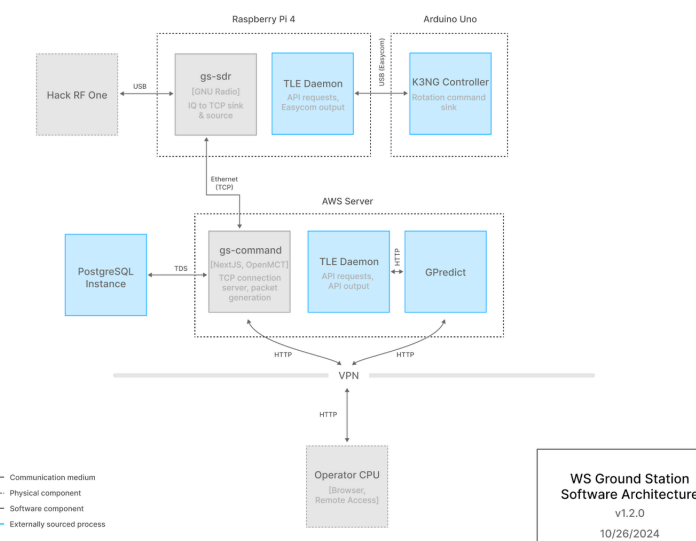

### Software Defined Radio

GS-1 uses a HackRF One as its software defined radio (SDR), as it is easily reconfigurable and upgradable. This SDR provides a wide frequency range (1MHz - 6GHz), is cost effective (\$300), portable (6.75"x4.25"x4.25"), and compatible with GNU Radio. It interfaces with the gs-sdr software module over serial connection and has an SMA coaxial feed-point to the front-end RF.

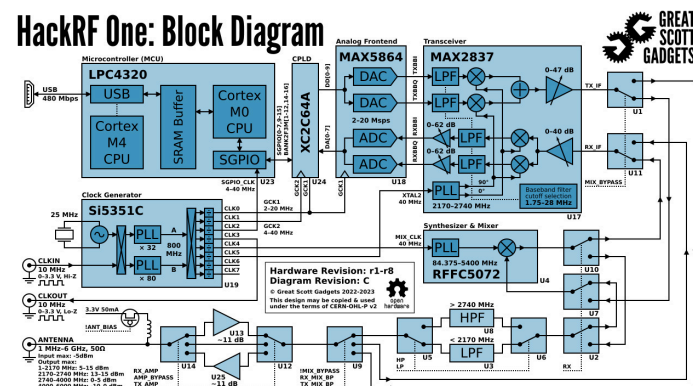

Block Diagram of GS-1 SDR

### Antenna

The antenna is a 3.6-meter circularly-polarized Yagi-Uda of 18 elements per polarization axis and target gain of 16-17dBiC. It is hand-tuned to account for the dielectric mounting materials in the delicate near-field. It is supported by a typical inline-component based RF architecture including low-noise and power amplifiers and analog filters.

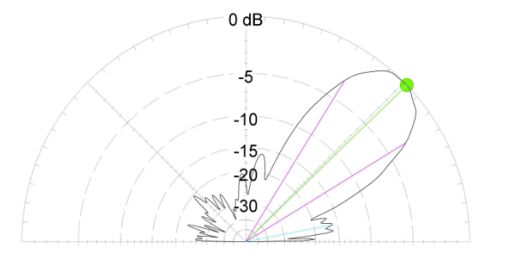

Gain Diagram for GS-1 Yagi



CAD of GS-1 Assembly

### Acknowledgements

This work is supported by WashU Satellite, McKelvey Engineering, ESE Department, and MEMS department. We extend our gratitude to our advisors, reviewers, and expert contacts who have been invaluable to us. Special thanks to James Buckley, Andrew Clark, Marion Sudvarg, Louis Woodhams, and all other advisors and mentors.

### Website



### References

